



**APPENDIX - G**

**1<sup>st</sup> APRIL**

**2019**

THIS DOCUMENT WILL SUPERSEDE ALL OTHER PREVIOUS VERSIONS OF APPENDIX G AND WILL BE EFFECTIVE UNTIL FURTHER NOTICE.

TO BE READ IN CONJUNCTION WITH THE NATIONAL SPORTING CODE (NSC) OF THE SRI LANKA AUTOMOBILE SPORTS.

NOTE: ALL OTHER MODIFICATIONS, NOT SPECIFICALLY ALLOWED HEREIN ARE PROHIBITED.

**SRI LANKA  
AUTOMOBILE  
SPORT**

## **APPENDIX G - 2019**

**THE INTERPRETATION OF THESE RULES AND REGULATIONS LIES WITH THE SLAS COUNCIL AND SUCH INTERPRETATION WILL BE FINAL AND BINDING.**

**In The event of any dispute or inconsistency arising out of The interpretation, the English text shall prevail**

**EFFECTIVE FROM 1ST APRIL 2019**

### **HOW TO UNDERSTAND AND USE “APPENDIX G”**

Example1 - For '**SLE**', '**SL N**' & '**SL H**' Classes:

First you read       - “Section 1 - General Specifications”  
Second you read     - “Section 3 - Regulations for Group N Production Cars”  
Third you read       - “Section 4 - Class Specific Regulations”

Example 2. - For '**SLA**', '**SL S**' & '**SL GT**' Classes:

First you read       - “Section 1 - General Specifications”  
Second you read     - “Section 4 - Class Specific Regulations”

**General Regulations** will be SUPERSEDED by the **Group Regulations**, both General and Group Regulations will be SUPERSEDED by the **Class Specific Regulations**.

**Only the following documents will be considered as authentic documentation when obtaining any specification for reference, which is not specified herein Appendix G.**

1. Manufacturer's Workshops manual/ Repair manual
2. Haynes Repair manual

# CONTENTS

# PAGE

## Section 1- General Specifications

G-01. Construction	1
G-02. Construction Requirements	2
G-03. Roll Cage	3
G-04. Driver Safety Equipment	5
G-05. Cockpit Safety Equipment	6
G-06. Other Details	7
G-07. Name and Blood Group	9
G-08. Groups	9
G-09. Classification by Cubic Capacity	10

## Section 2- Groups and Classes

2.1 Groups and Class classifications	11
--------------------------------------	----

## Section 3- Regulations & Technical Specifications

3.1 Regulations for Group N Production Cars	12
---	----

## Section 4- Class Specific Regulations & Technical Specifications

4.1 Class Specific Regulations for GROUP E cars up to & including 1000cc (One Make- Nissan March)	15
4.2 Class Specific Regulations GROUP E cars up to and including 1275cc (One Make- Mini 1275cc)	17
4.3 Class Specific Regulations GROUP E cars up to and including 1300cc	20
4.4 Class Specific Regulations GROUP N cars up to and including 1300cc	22
4.5 Class Specific Regulations GROUP N cars up to and including 1500cc	24
4.6 Class Specific Regulations GROUP A cars modified 1000	26
4.7 Class Specific Regulations GROUP A cars Mini 7 One Make	28
4.8 Class Specific Regulations GROUP H cars SLH 1600 (One Make- Honda Hatch Back)	31
4.9 Class Specific Regulations GROUP H cars SLH 2000 (One Make- Subaru Legacy)	36
4.10 Class Specific Regulations GROUP GT cars up to 3500cc	38
4.11 Class Specific Regulations GROUP T&J	43
4.12 Class Specific Regulations GROUP S up to and including 1500cc	45

## Section 5- Formula Cars

5.1 Formula McLarens 1300cc	45
5.2 Modified Formula Cars up to 1665cc	45
5.3 Formula Ford 1600	45
5.4 Formula Ford 1600 Pre -1974	57

# SECTION 1

## GENERAL SPECIFICATIONS

### APPENDIX "G" – CLASSIFICATION OF AUTOMOBILES 2019 (Other than Karts)

These regulations shall apply to all automobiles other than Karts. The word "car" used in these regulations shall have the same meaning as the word automobile. All regulations mentioned under General Specification shall apply to all Groups and Classes.

**All competitors should be familiar with the Appendix C available on the SLAS website, for license categories for respective classes.**

#### G-01. CONSTRUCTION

**1.1 BODY SHELL/ CHASSIS:** The major structural part of the homologated vehicle, constructed of all parts which are permanently attached (by welding, brazing, bonding etc., around which are assembled the mechanical components and the bodywork. Components or panels which are attached by means of removable fasteners are not considered to be part of the body shell. The fitting of underbody protections is authorized in rallies only, provided that these really are protections which respect the ground clearance, which are removable and which are designed exclusively and specifically in order to protect the following parts: engine, radiator, suspension, gearbox, tank, transmission, exhaust, extinguisher bottles. These protections must be made from either aluminum alloy or steel and have a minimum thickness of 4 mm and 2 mm for steel. Nevertheless, it is possible to reinforce the upper part with metal or composite ribs and to add non-structural composite parts. Underbody protections may extend the whole width of the underside part of the front bumper only in front of the front wheel axis. For Formula cars the Chassis/Frame should be of tubular Steel construction and of adequate strength.

The Silhouette and Plan View must remain as per the original design. The wheel archers/ fenders may be extended, however the wheel rim or the Tyre cannot be jutting out of the fender when the wheels are straight.

#### **1.2 BODY PARTS:**

- (a) Components or panels not considered to be part of the body shell, which are attached by means of removable fasteners are not considered to be a part of the body shell.
- (b) All Cars (except formula) should have the bonnet stay Rod.
- (c) For all classes Front and rear Bumpers can be replaced by proper bumpers Similar or Identical to the original Bumper. However only bumpers manufactured out of fiberglass or plastic will be allowed to be used as replacement bumpers. Front fender design cannot be changed, material could be fiberglass or plastic.

**The chief scrutinizer of the Meet may exclude an Automobile, the construction of which is deemed to be not fit to race or dangerous.**

**G-02. CONSTRUCTION REQUIREMENTS - All Automobiles to which these regulations apply:**

- 2.1 Wheels** - have four complete wheels, of which at least two are used for steering and at least two for propulsion (excluding the spare).
- 2.2 Brakes** - Be equipped with brakes which comply with statutory requirements as to construction of motor vehicles, or if there is no mechanical system available for applying braking effort to at least two wheels, there shall be two hydraulic systems so that in the event of failure of one system, braking on at least two wheels remain effective. Dual circuit hydraulic systems are mandatory. **Upgrading of Brakes parts with OE (same make of vehicle) will be allowed. (unless specified in class regulations).**
- 2.3 Steering Wheel** - Have a steering wheel, which has a full diameter rim. Aircraft type wheels are not permitted. (Except for Formulas).
- 2.4 Front Windscreen Glass** - All cars must be fitted with a Glass Windscreen, polycarbonate is strictly prohibited. (Except Formulas).
- 2.5 Seat & Mounting** - Non Reclinable racing seat is compulsory for all classes. If used, the seat Railings have to be proper mounted.
- 2.6** Have a protective bulkhead between the engine and the driver's/ passenger's compartment, suitable and sufficient in the case of fire for preventing the passage of flames.
- 2.7 Driver's/ passenger's compartment** - Have a complete floor rigidly supported and of adequate strength within the driver's/passenger's compartment.
- 2.8 Fuel Tank** - Have the fuel tank mounted outside the Drivers/Passenger compartment (in the case of hatchback/ saloon type vehicles a protective bulkhead fabricated with steel or Aluminum between the luggage and passenger compartment is required if the fuel tank is fitted inside the luggage compartment of the car and have any fuel line(s) or vents passing through the driver's/passenger's compartment covered or enclosed in a solid metal cover. All openings situated within the interior body panel behind the driver's compartment should be covered. (Refer specific class regulations for further details). A non-return valve to be fitted on all fuel tank breather pipes to prevent the fuel moving out of the tank in case of overturn or collision or any other matter.
- 2.9 Exhaust** - Have the exhaust system outside the driver's/passenger's compartment or beneath the floor of the car or secured in casings or covers of solid metal.
- 2.10 Bonnet** - Except rear-engine single seated Racing Cars, have a bonnet or casing of metal or if original, solid non-inflammable material covering and/or surrounding the engine and which is secured by fastenings of adequate strength and positive locking action.

- 2.11 Doors** - Have secure fastening for all doors and all hinged or detachable parts of the bodywork. Door Interior panels and Bars could be removed.
- 2.12 Glasses on Door and side panel** - can be substituted with Polycarbonate a minimum Thickness of 4mm (front and rear Windscreen has to remain glass).
- 2.13 Suspension** - Be fitted with sprung suspension between the wheels and the chassis. The suspension and steering movement shall be controlled to avoid the road wheels fouling any part of the car. **Upgrading of Suspension is allowed, mounting positions to be remained unchanged and camber adjustments are permitted. (unless specified in class regulation).**
- 2.14 Mirrors** - Be fitted with Door / Wing Mirrors on either side of the vehicle. Also with one mirror of a reflective surface as a rear view mirror within the car of at least 50 sq. cms, securely mounted in the original position as to give a clear view to the rear. The mirror glass shall be enclosed in a suitable frame with no sharp edges exposed such as would cause injury in the event of an accident.
- 2.15 Radiator** - Radiator size, shape and mounting point are free, number of fans are free. (unless specified in group or class regulations)

**G-03. ROLL CAGE (If a closed car):**

Have a FIA homologated 6 point roll cage securely mounted inside the car or have a Roll cage of adequate strength mounted onto the chassis or body shell of the car. All joints of the cage have to be welded or Bolted (Mig Welding is Recommended). This roll cage must be braced to resist collapse in all directions and must be manufactured so that the top of the roll cage is at least 5 cms above the driver's helmet when the driver is in the normal driving position. For all classes the Minimum outer Diameter of the pipes used should be 1 1/2 inches (38.1MM) and the Minimum Thickness of the material used should be a minimum of 1.6MM. The material should be of Steel Pipes or UN alloyed carbon steel tubing both of which should be none seam welded in between two joints.

When mounting the Roll Cage to the Chassis/ Floor Board of the car a minimum base of 4x4 inches is recommended.

The Roll cage may be Welded or Bolted to the Floor Board of the car. If bolted a counter plate measuring the same size (4x4 inches) as the base must be fixed to the car.

The following design of the ROLL CAGE IS RECOMMENDED (**Refer Image N/1 for design of roll cage**) A hole should be drilled with an 7mm size drill bit on the left side of the roll cage in order to measure its thickness. (Refer point "M" on roll cage diagram/ drawing). If the roll cage is being painted an area of 2 inches either way should be left bare (without paint) from where the hole is situated.

- For Hill Climbs, Autocross Meets, Circuit Meets, Road Races and Special Stage Rallies a 6-point Roll cage is Mandatory.
- For TSD Rallies a 4 point Roll cage is Mandatory.
- Effective means of ventilating the driver's/passenger's compartment.
- Operable means of access (from both inside and outside) on either side to the driver's/passenger's compartment sufficient in size for removal of the occupant.

**Image N/1**

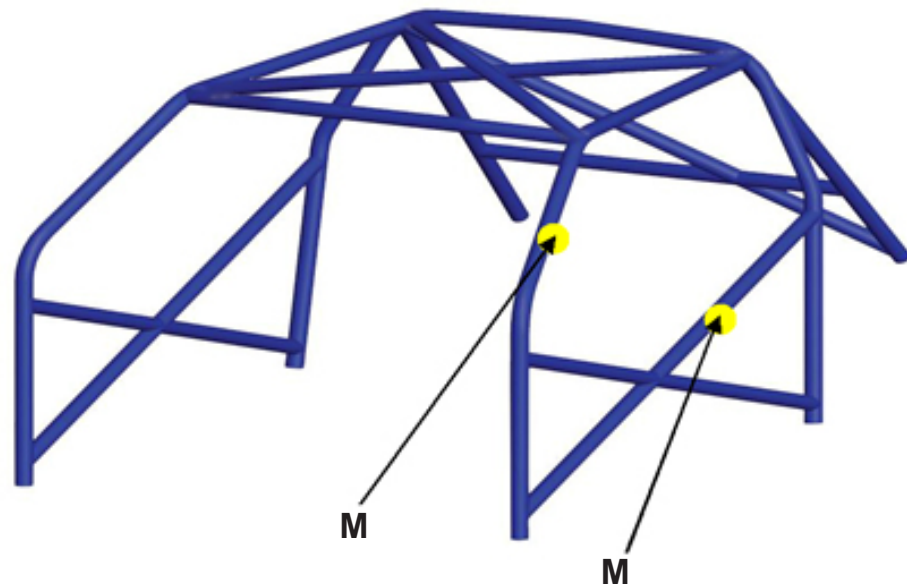

**If an Open Car:**

4 point Roll Cage of adequate strength mounted onto the chassis or body of the car. This roll bar must be braced to resist collapse in all directions and must be manufactured so that the top of the roll bar is at least 5 cms above the driver helmet, when the driver is in the normal driving position.



## G-04. DRIVER SAFETY EQUIPMENT

FIA Approved Racing Suit, Helmet, Balaclava, Shoes & Hans Device is Mandatory for all classes. (Refer Appendix G Minimum safety standards ).

**Safety Harness:** Be fitted with a safety harness belt of at least 4 points, with a central release. Compulsory for all classes (EXCEPT TSD) a minimum of 2 points of the belt should be securely mounted to the Chassis of the car according to diagram and specs given. Lap Straps are prohibited. **(2/3 point seat belts are prohibited)**. The belts cannot be mounted to the same bolt with which the seats are bolted to the frame.(Refer images)

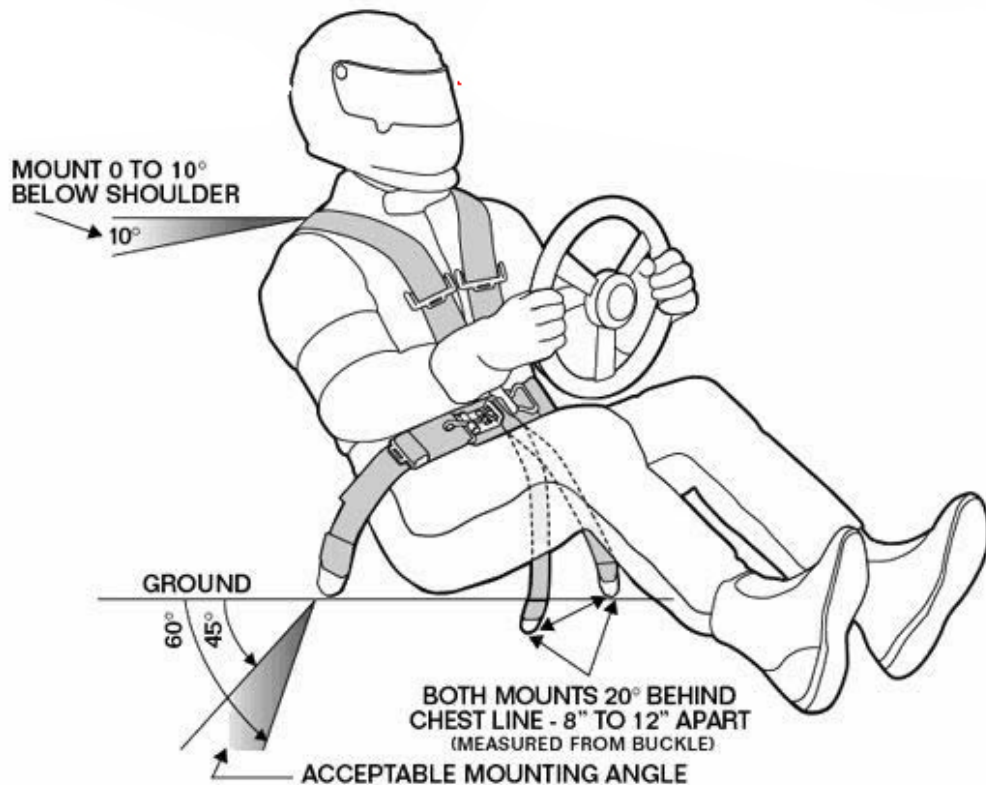



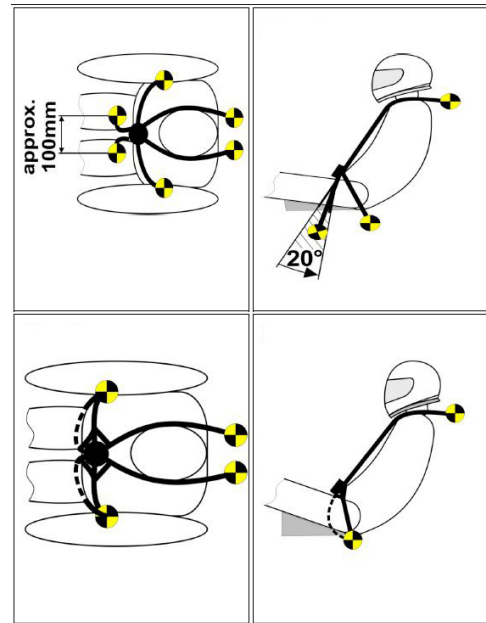
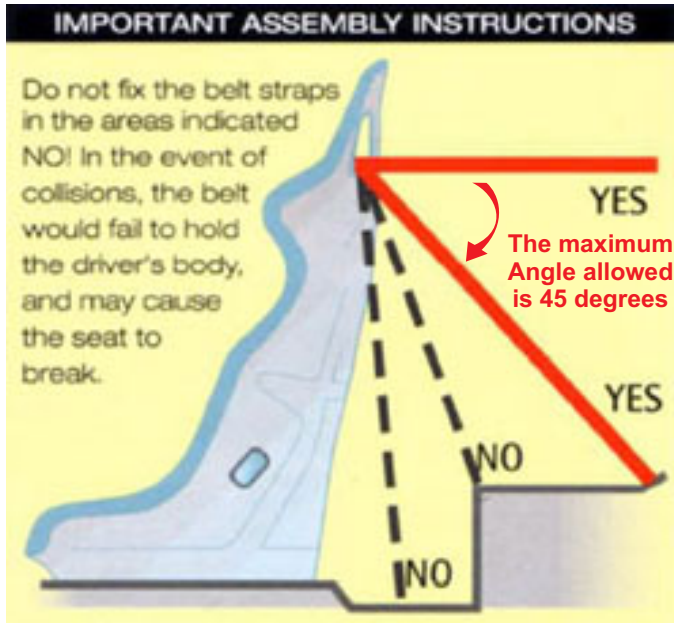

**G-05. COCKPIT SAFETY EQUIPMENT**

- 5.1 Competition seat in compliance with **FIA Standard 8855-1999** as guideline.
- 5.2 Harness in compliance with **Appendix G Minimum Safety Standards**.
- 5.3 Hand-held extinguisher for circuit events with Validity certificate from a service provider and a Meter showing the condition of the extinguisher is compulsory.
- 5.4 Roll-cage padding made out of suitable compressed foam can be used.
- 5.5 Fire extinguisher containing 1.00 Kg AFFF extinguisher. It should be mounted securely. This will be applicable for all motor racing events, however for speed rallies Fire extinguisher containing 2.00 Kg AFFF extinguisher is compulsory. If a Fire extinguishing system (properly wired and fixed) is installed within the car the Extinguisher can be mounted according to a given diagram by the manufacturer or to facilitate the length of the tubing.



## G-06. OTHER DETAILS

- 6.1 Except for rallies, have all hubcaps, number plates and wheel embellishes removed. All glass lenses to be taped down to prevent their shattering.
- 6.2 To have a general circuit breaker that will cut all electrical circuits, battery, alternator or dynamo, lights, hooters, ignition, electrical controls etc. and must also stop the engine is compulsory. It should be spark proof and should be accessible from inside and outside. AS for the Outer the triggering system of the circuit breaker will compulsorily be situated at the lower part of the windscreen mounting frame on the left side for closed body cars (Right Hand drive).



- 6.3 **Battery** - All batteries' which are mounted within the passenger compartment and the luggage compartment should be securely covered with a non-conductive solid material. (Paper based material prohibited), and should be properly mounted.
- 6.4 **Lights** - The original headlights can be made inoperative and covered with adhesive tape or alternately removed. The side lights may be removed. However except in formula type cars, the working brake lights should remain. In addition for all cars an indicator light (permanent red light – Bulb 21W) must be fixed in a central position at the rear at approximately the height of the rear parcel tray. Working/ operative brake lights are compulsory. The original mounting positions of the tail light/ brake lights have to be retained. **(Unless specified in specific Regulation) LED and aftermarket lights as brake lights are strictly prohibited unless factory fitted by manufacturer.** Further apart from the original brake lights 2 additional brake lights have to be fitted on either side of the permanent light at the parcel tray height of which the size should be identical or larger than the permanent light. (All 4 brakes lights should work together). The Permanent light should be wired to work with the ignition switch. **(4 Brake lights will be compulsory for all Gravel Circuit Meets, Tarmac Circuit Meets and Rallies)** LED lights will be allowed only as a permanent light and for the 2 newly added brake lights to be fitted together with the permanent light. (Size 3inches x 4inches or larger). **LED strips only are prohibited.**

- 6.5 Throttle Body** - have on each throttle, whether butterfly, slide or other type, a return spring which in the event of the throttle linkage becoming detached will in all cases return each throttle to the closed position **(Not applicable to cars fitted with electronic or fly-by-wire throttle systems)**.
- 6.6 Tires** - Be fitted with tires which have not been re-treaded, recapped, repaired or in any way are re-conditioned.
- 6.7 Seat Mounting** - Seat supports must be attached to the shell/chassis via at least 4 mounting points per seat, using bolts with a STEM LENGTH of a minimum diameter of 8 mm and counter plates.
- 6.8 Tow hook** - At all Meets, all automobiles (Except Formula cars) must be fitted with front and rear tow hooks. Tow hook position should be highlighted and indicated clearly.



- 6.9 Mud flaps** - Rear mud flaps are mandatory at all rallies, circuit meets, super cross and autocross events (Gravel). Mud flaps minimum thickness 4mm and should be broader than the tire being used. The flap cannot be sagging and minimum height from ground level should be 6 inches. If at any race meet there are two races of the same class irrelevant of the conditions mud flaps will be compulsory for both races.
- 6.10 Fuel** - Only “fuels” commercially retailed in Sri Lanka & currently available at Ceylon Petroleum Corporation (CPC) and Indian Oil Company (IOC) are permitted to be used. The highest grade of fuel that can be used is Aviation Gasoline. **No additives or oxides are permitted.**

All Competitors (Except group F and group T&J) should make sure to retain a minimum of 8 liters of fuel in the fuel tank at the end of each event during the following as a mandatory requirement, Competitors failing to do so will be liable for immediate disqualification and or **(Refer Supplementary regulations)**

- (a) Closed Circuit meets (Tarmac/ Gravel) (Each race)
- (b) Hill Climbs (each Run)
- (c) Road Races

**6.11 Windscreen/ Glasses** - The Front, Rear And Side Glasses Should Be Free From Any Sponsor Stickers. All glasses should be clear or transparent, tinted & or shaded glasses are strictly prohibited. Sponsor Stickers Maximum 6 Inches Wide At the Top of the Front Windscreen and Maximum 6 Inches Wide at the Top of the Rear Glass Are Permitted. The Driver Should Be Visible From Behind and the Side.

**6.12 Passenger Seat** – Except for Rallies, All front and rear Passenger Seats Have to be removed.

**6.13 Power Steering** – Can Be Disconnected.

**6.14 Rims & tires** - all 4 Rims should be of the same size, similar design and of the same offset (Except for Formulas, SL GT, SL S and SL H classes). All 4 Tires should be of the same size, Make and Compound.

#### **G-07. NAME AND BLOOD GROUP**

The Name and blood group (as specified on SLAS license) should be displayed on the car. For Closed Circuit meets (Gravel and Tarmac) For Road Races, Hill Climbs and Rallies the Name and Blood Group should be displayed on the Rear Left and Right side door glass only. (If Hatch back or a two door car on the rear side glass)(For Rallies, Driver and Navigator should be clearly marked) Name/s and blood group/s cannot be displayed in any other area.

The height / Font Size of the Name and Blood Group should be 5cm and can be displayed only in White color. Name and Blood group written over any tape will not be permitted. No sponsor stickers will be permitted in this area. For Hill Climbs if a car is shared, both names and blood groups should be displayed.

#### **G-08. GROUPS**

Cars competing in events shall be distributed / Categorized into the following groups.

- (a) **Group E** : Entry Level
- (b) **Group N** : Production Cars – Standard
- (c) **Group A** : Production Cars – Modified
- (d) **Group S** : Specials
- (e) **Group H** : SLAS Homologated Cars
- (f) **Group GT** : Grand Touring Cars
- (g) **Group T&J** : Trucks, Jeeps, Double Cabs, Single Cabs and SUV's. (Estates and station wagons are excluded).
- (h) **Group F** : Formula Cars

**A vehicle cannot be classified in more than one Group. Upgrading is not allowed for one make events.**

**G-09. WHERE CLASSIFICATION IS BY CUBIC CAPACITY:**

In the case of supercharging or turbo-charging, the normal cylinder capacity will be multiplied by 1.7 and the car will pass into the class corresponding to the fictive volume thus obtained. In the case of rotary engines, the capacity (cc) will be deemed to be the equivalent to twice (x2) the volume of the working chamber.

**GENERAL REGULATIONS  
WILL APPLY TO ALL CLASSES  
UNLESS SPECIFIED IN  
CLASS REGULATIONS.**

## **SECTION 2**

### **GROUPS AND CLASSES**

**Mandatory Requirements for All Classes** - All Competitors Participating in any of the SLAS approved race meets should strictly comply with the Minimum Safety standards, in relation to the race gear (**Appendix G Minimum Safety Standards**).

Competitors may apply in writing and obtain prior approval of the Council of SLAS to include any car event/s provided a minimum of ten vehicles are assured with the proposal.

#### **2.1 Group and Class classifications**

##### **Group E**

- **SLE Cars up to 1000cc** – one make Nissan March (Entry Level)
- **SLE Cars up to 1300cc** – Ford Laser/ Mazda 323 BD, BE, BF  
Hatch backs & Sedans (Entry Level)
- **SLE Cars up to 1275cc** – Mini one Make (Entry Level)

##### **Group N**

- **SLN Cars up to Cars up to 1300 cc** - Ford Laser / Mazda 323 - BD, BE, BF,  
Hatch backs & Sedans
- **SLN Cars up to Cars up to 1500 cc** - Ford Laser / Mazda 323 - BD, BE, BF  
Hatch backs & Sedans

##### **Group A**

- SLA 1000
- SLA Mini 7

##### **Group S**

- SLS Cars up to 1500cc

##### **Group H**

- SLH Cars up to 1600 (One make – Honda 3 door Hatch back Cars only)
- SLH Cars up to 2000 (One Make - Subaru Legacy )

##### **Group GT**

- Cars up to 3500cc

##### **Group T&J -**

(Trucks, Jeeps, Double Cabs, Single Cabs & SUV's. (Estates & station wagons are excluded.))

- Diesel up to 5500cc
- Open for Diesel & Petrol Vehicles (SUV's Allowed)

##### **Group F**

- Formula McLarens 1300cc CARB
- Formula McLarens 1300cc EFI
- Formula Cars up to 1600cc (Ford Formula)
- Formula Cars Up to 1665 cc (Modified)

## **SECTION 3**

### **GROUP REGULATIONS & TECHNICAL SPECIFICATIONS**

#### **3.1 REGULATIONS FOR GROUP “N” PRODUCTION CARS**

##### **3.1.1 DEFINITION**

Large scale series Production Cars, equipped with normally aspirated engines.

##### **3.1.2 HOMOLOGATION**

At least 2,500 identical examples of these cars must have been manufactured in 12 consecutive months (One-Make Series classes are excluded from this rule). Proof of which should be produced.

##### **3.1.3 NUMBER OF SEATS**

Cars must be at least a two seater whilst being manufactured.

##### **3.1.4 MINIMUM WEIGHT AND NETT POWER**

At the time of homologation, the SLAS Classification Committee of the Sri Lanka Automobile Sports (SLAS) will establish the minimum weight for each make and model of car, based on the manufacturer's net weight. Where a particular model of car has several weights declared, the SLAS will establish the lowest weight applicable in each case, and the competitor will be permitted to reduce the weight in accordance with the rules applicable in the SL-N Group.

##### **3.1.5 ENGINE**

###### **(a) Cylinder-Block, Cylinder-Head:**

The Series Production Engine should be retained. Maximum re-bore allowed is the second oversize, in relation to the original bore, unless specified under individual class rules. The re-sleeving of the engine is allowed within the conditions as for re-boring and the sleeve material modified. Planning of the cylinder block will be allowed up to a maximum of 0.50 mm. **reducing the cubic capacity of a series production engine is strictly prohibited.**

###### **(b) Ignition:**

The make and type of the spark plugs and high-tension leads are free. The Wire Harness is Free.

###### **(c) Cooling System:**

Radiator size, make and fan is free. **(Unless specified in class regulations)**

###### **(d) Carburetors:**

The original system and type of carburetor must be retained. The operating principal of the carburetor venturi doors has to retain. The components of the Carburetor which control the quantity of petrol entering the combustion chamber may be modified, provided that they do not have any influence over the quantity of air admitted. Air filter(s) are free and they may be removed however the original air cleaner housing should be retained.

- (e) **Injection:**  
The original system must be retained. Components of the injection system situated Downstream of the air-flow measuring device, and which control the quantity of petrol. Entering the combustion chamber may be modified but not replaced, provided that they do not have any influence over the quantity of air admitted. The injectors may be modified or replaced in order to modify their flow rate, but without modifying their operating principle and their mountings. The injector rail may be replaced with another of free design.
- (f) **Lubrication:**  
The fitting of baffles in the oil sump is authorized.
- (g) **Engine Mounts:**  
The material of the engine mountings is free.
- (h) **Exhaust:**  
Exhaust free, original cast-iron exhaust manifold should be retained.
- (i) **Cylinder Head Gasket:**  
The material is free. **(Unless specified in class regulations)**
- (j) **Flywheel:**  
The original flywheel should be retained. **(Refer class Regulations)**
- (k) **Cruising Speed Controller:**  
This controller may be disconnected.

### 3.1.6 CLUTCH & TRANSMISSION

- (a) **Clutch:** Make and Material is free. **(Unless specified in class regulations).**
- (b) **Gear Box:** The original gear box ratios should be retained, No modifications are permitted **(Refer class regulations)**
- (c) **Final Drive:** The final drive ratio should be as per the manufacturer's specification,

No changes can be made, but in the event of One-Make Series they will be specified. **(Refer class regulations)**

### 3.1.7 SUSPENSION

Upgrading of Suspension is allowed, mounting positions to be remained unchanged and camber adjustments are permitted. **(Unless specified in class regulation).**



### **3.1.8 WHEELS AND TYRES**

**Wheels** - Free. (Unless specified under particular class rules) Hubcaps must be removed.

**Tires** - The size of the tire and the word "Competition tires" are specifically excluded, except in "Off-track" (gravel and rallies etc.). The tires may be changed from the manufacturer's specification provided that the aspect ratio is equal to or greater than 50%, unless otherwise specified by the manufacture. By this rule, slicks, semi slicks/special racing tires are specifically excluded.

### **3.1.9 BRAKING SYSTEM**

**Brake linings:** Free, as well as upgrading brakes are permitted with OE parts (Same make of vehicle). Protection plates may be removed or bent. In the case of a car fitted with servo-assisted brakes, this device may be disconnected. The same applies for anti-lock braking systems.

**(Refer G-02/2.2 - Page 2)**

**Hand-brake:** The mechanical hand-brake may be replaced with a hydraulic system.

### **3.1.10 BODY, SHELL AND CHASSIS**

No modifications may be made to the manufacturer's design of the series production body shell and/or chassis. Reinforcements, in the form of crash or similar bars inside or outside, are not permitted except for the fitting of a Roll Cage.

### **3.1.11 LIGHTING SYSTEM**

The tail lights and Brake lights have to remain in its original mounting position and be in operating condition unless otherwise specified in specific rules for classes. **(Refer G-06/6.4 - Page 7)**

### **3.1.12 BATTERY**

Free. However, must be securely fixed and covered to avoid short-circuiting and leaks.

### **3.1.13 FUEL**

Will be restricted to commercially available fuel, Nitrous and other oxides are not permitted.

### **3.1.14 AIR CLEANER**

Air filter element is free, air filter housing should remain. **(Unless specified in class regulations)**

## SECTION 4

### CLASS SPECIFIC REGULATIONS & TECHNICAL SPECIFICATIONS

#### 4.1 Class Specific Regulations for GROUPE cars up to and including 1000 cc

(One Make – Nissan March - Grade C License Holders Only)

**These rules should be read in conjunction with GROUP N Regulations**

##### 4.1.1 Engine Specifications

**Bore** - 71 mm

**Stroke** - 63 mm

Using up to maximum of 0.50mm on 2nd oversize from the standard size pistons is allowed. Additional cc from using 2nd oversize pistons is allowed.

**Head Height** - 120 mm (minimum)

**Block Height** - 191 mm (minimum)

**Throttle body Diameter at butterfly side (Manifold side)** – Max 46 mm

**Inlet valve diameter** - 27.5mm +\_ 0.2 mm (tolerance)

**Exhaust Valve diameter** - 22.5mm

**Cam Lobe dimensions** - Inlet Lobe Height 38mm – Base Circle 32 mm,  
- Exhaust Lobe Height 38mm – Base Circle 32 mm

**Valve Springs wire Diameter** - Inlet 2.7 mm, exhaust 2.7 mm

**No of coils** - Inlet 8, Exhaust 8



### **Intake port**

– 37 mm , 30 mm, 20 mm +/- 1 mm ( caliper should be placed on the outer edge of the port)



### **Exhaust port**

– 33 mm, 25 mm +/- 1 mm



## **4.1.2 Transmission**

**Final drive ratio** of 4.47 (maximum allowed)

**Gear Ratios-** Nissan March series gear box should be used (K10, k11 can be interchanged with newer models but gear ratios should as per Nissan march K11 and k10 series.)

**Clutch** - Aftermarket not permitted.

**Fly wheel** - minimum weight should be 6 kg

**LSD** -After Market not permitted.

## **4.1.3 Tires**

Racing tires, Slicks or Semi Slicks not permitted. 175 or 185 x 70 x 13 (**Only CEAT tyres will be permitted for Tarmac Circuit, Road Races and Hill Climbs Events**) \* Please contact the SLAS secretariat for information on obtaining tyres.

## **4.1.4 Air filter, cooling system & wiring harness and ECU free**

## **4.1.5 Weight**

MINIMUM CLASS WEIGHT 835 kg (with Driver)

## 4.2 Class Specific Regulations for GROUP E cars up to and including 1275cc

(One Make Mini 1275cc - Grade C License Holders Only)

### These rules should be read in conjunction with GROUP N regulations

All cars must be raced with standard Mini 1275 cc, non-Cooper/S engines and gearbox. No alternations are allowed on the Engine, Cylinder Head or Gearbox for that model apart from those modifications specifically allowed below.

These rules shall apply to Mini / Mini clubman cars manufactured up to 2000.

#### 4.2.1 ENGINE

Standard 1275 cc Cylinder block is mandatory. All '12A''12H' series blocks.

It is permitted to convert a car normally supplied or homologated as a 850 cc / 998 cc/1275 cc (or vice versa) provided that all the elements that would have had to have been present in the original form of the vehicle according to these regulations are still present after conversion.

The Connecting Rod Can only be replaced with part # BHM 1137

**Bore -**  $(2.78\text{in} + .060\text{in} = 2.84\text{in})$   $70.61\text{mm} + 1.5\text{mm} = 72.14\text{mm} \times (3.2)$   
81.28mm (1275 cc) Maximum bore size permitted  $70.61 + 1.5\text{mm} =$   
72.14mm

Only the Standard mini 1275cc (12G940) Cylinder Head must be retained. The Ports of the Original / above mentioned 1275cc Cylinder heads may be enlarged. 12A & 12H engine blocks will be permitted. Minimum bore diameter permitted is (+ 60 piston) 72.14.

#### Pistons and rings:

[minimum of 3 rings] must be of original specification and material and cannot be modified. The pistons can be flush with the block face, but no part of it can protrude beyond the block face.

The original / standard piston can only be replaced with unmodified aftermarket pistons.

#### Connecting Rod :

can only be replaced with part number:

A Series	2 Nos.	12G123	} Gudgeon Pin
	2 Nos.	12G126	} Bush Type
A+ Series	2 Nos.	12A1997	
	2 Nos.	12A1999	} Fi Type

### **Crankshaft**

Any production Mini with standard stroke 81.28 mm permitted.

**Cooper S Crankshafts Part Nos: 12 A 595, 12A1454, BHM 1436 NOT allowed**

### **Camshafts**

#### **Camshaft standard.**

Checking Clearance 0.017 in

**Inlet Valve Lift** - 0.263 in

**Exhaust Valve Lift** - 0.263 in

**Camshaft Duration:** Inlet 230 degree

Exhaust 252 degrees

**Lobe center angle:** Inlet 106 degree

Exhaust 109 degrees

**Optimizing valve timing is permitted.** Provided the original wheels are retained. The use of venire adjustments is prohibited. Valves and springs – Double Valve Springs Permitted. Inlet 33.32mm dia., Exhaust 29.38mm dia. (as per specs of Haynes Manual)

## **4.2.2 INDUCTION SYSTEM**

A single 1.75" mm SU HS6 Carb or single 1.75' (HIF 44) carburetor is permitted. The air filter element free.

## **4.2.3 EXHAUST SYSTEM**

The exhaust system is free.

## **4.2.4 IGNITION SYSTEM**

The ignition system shall only be with a contact breaker system. The ignition distributor should be as fitted as standard. Nos. 25D4 / 45D4 / 49D4 / 59D4 / 65DM4. Electronic ignition allowed.

The use of magnetic field electrical breakers will be permitted in place of platinum electrical breakers.

## **4.2.5 COOLING**

The standard engine driven cooling fan should be retained in original working order.

## **4.2.6 TRANSMISSION & CLUTCH**

The combined weight of the flywheel and clutch assembly [clutch plate and back plate] should not be less than 5.9kg.

Prohibited Aluminum or competition flywheel / racing gears

## **GEAR RATIOS**

Final Drive STD helical cut 3.211 RATIO (pinion 19-teeth and crown wheel 61 teeth). [A+ Series]

The 29-tooth Primary Gear and the 29-tooth Input Gear must remain standard along with the intermediate gear [idler]

37-tooth and must not be interchanged with any other ratios.

The intermediate gear must remain standard. (29:37:29)

**Prohibited- Locked, torque reducing or any form of limited slip diff prohibited.**

**The replacement of any gears from the main gear cluster and lay gear as fitted to the Mini 1000 that will in any way alter the ratios is not allowed.**

### **4.2.7 SUSPENSION**

Rear radius arms cannot be lightened or altered. The vehicle may be lowered by alteration of cone/doughnut only. The original shock absorber length, mounting points and supports cannot be changed. Only pressure Adjustable shock absorbers Allowed. Negative Camber allowed.

### **4.2.8 BRAKES**

**Minifins not allowed.**

### **4.2.9 WHEELS, TYRES & STEERING**

Wheel width and size: up to 6 inches by 10 inches (Gravel) OR 12 inches (Tarmac). The drilling or grooving of any brake parts. Split-rimmed wheels are prohibited.

Racing tires, Slicks or Semi Slicks not permitted. 155 x 65 x 12 (**Only CEAT tyres will be permitted for Tarmac Circuit, Road Races and Hill Climbs Events**) \* Please contact the SLAS secretariat for information on obtaining tyres.

### **4.2.10 WEIGHT**

MINIMUM CLASS WEIGHT 695 kg (with Driver)

### **4.3 Class Specific Regulations for GROUP E cars up to and including 1300cc**

(One Make Ford Laser/Mazda 323 - Grade C License Holders Only)

**To be read in conjunction with Group N Regulations**

#### **Body shell and Chassis**

Only BD, BE, BF series 4-door sedan/ hatchback.

**NEW "C" CATEGORY LICENSE APPLICANTS IN 2020 CAN ONLY RACE "BF" SERIES 4 DOOR SEDAN/ HATCHBACK.**

#### **4.3.1 Engine**

E3 (chain driven single or dual)

**Bore** - 77 mm / Stroke 69.6 mm / CC 1297

Maximum re-bore allowed is the second oversize specified by the manufacturer (.50) in relation to the original bore, The re-sleeving of the engine is allowed within the conditions as for re-boring and the sleeve material modified. Planning of the cylinder block and the cylinder head will be allowed up to a maximum of 0.50 mm. However the maximum cylinder capacity increased due to re-boring cannot exceed 1314cc.

#### **Cylinder head Port sizes**

Intake Port Maximum size: 33mm Tolerance: +/- 0.6mm

Exhaust Port Maximum size: 28mm Tolerance: +/- 0.6mm

Valve Spring Thickness and Height is free (Double springs are prohibited)

#### **Compression Ratio**

Increase in Compression Ratio up to a maximum of 9.5:1 Permitted by facing of cylinder head or block only.

#### **Camshaft**

Camshaft must remain as per manufacturer's specifications.

#### **4.3.2 Transmission**

Standard (Ratios 1st Gear 3.416, 2nd Gear 1.842, 3rd Gear 1.290, 4th Gear 0.918, 5th Gear 0.775).

**Final Drive Ratio** 4.105

**Flywheel** Minimum weight 7 kg.

**Clutch Diameter** – 184mm

### 4.3.3 Suspension

Suspension is free, however mounting points must remain as per Manufacture specifications. Negative Camber is allowed.

### 4.3.4 Wheels & Tyres

Racing tires, Slicks or Semi Slicks not permitted. 175 or 185 x 70 x 13 **(Only CEAT tyres will be permitted for Tarmac Circuit, Road Races and Hill Climbs Events)** \* Please contact the SLAS secretariat for information on obtaining tyres.

**Wheel Size 5.5J x 13 (Spacers are strictly prohibited)**

### 4.3.5 Lighting system

The original tail lights or lights of similar size have to be fixed in its original mounting points. Modified or individual lights will not be permitted.  
**(Refer G.06/6.4 - Page 7)**

### 4.3.6 Weight

MINIMUM CLASS WEIGHT 900 kg (with Driver)

**NOTE:** Current BD, BE series 4-door sedan/hatchback must be subjected to a Pre-scrutinizing to check race worthiness and be certified, this process will be done on two occasions during a year.

If a car/cars are involved in a racing accident and determined by SLAS to be rechecked, the car/cars involved must obtain a fresh Pre-Scrutinizing certificate after completing the repair prior to Racing the vehicle in any race meet.

**\* CARS NOT CERTIFIED BY 2020 WILL NOT BE ALLOWED TO RACE.**

**\* Please contact the SLAS secretariat for information.**



#### **4.4 Class Specific Regulations for GROUP N cars up to and including 1300cc**

(One Make Ford Laser/Mazda 323 - Grade B License Holders Only)

##### **To be read in conjunction with Group N Regulations**

##### **Body shell and Chassis**

Only BD, BE, BF series 4-door sedan/ hatchback.

##### **4.4.1 Engine**

E3 (chain driven single or dual)

**Bore** - 77 mm / Stroke 69.6 mm / CC 1297

Maximum re-bore allowed is the second oversize specified by the manufacturer (.50) in relation to the original bore, The re-sleeving of the engine is allowed within the conditions as for re-boring and the sleeve material modified. Planning of the cylinder block and the cylinder head will be allowed up to a maximum of 0.50 mm. However the maximum cylinder capacity increased due to re-boring cannot exceed 1314cc.

##### **Cylinder head Port sizes**

Intake Port Maximum size: 33mm Tolerance: + / - 0.6mm

Exhaust Port Maximum size: 28mm Tolerance: + / - 0.6mm

Valve Spring Thickness and Height is free (Double springs are prohibited)

##### **Compression Ratio**

Increase in Compression Ratio up to a maximum of 9.5:1 Permitted by facing of cylinder head or block only.

##### **Camshaft**

Camshaft must remain as per manufacturer's specifications.

##### **4.4.2 Transmission**

Standard (Ratios 1st Gear 3.416, 2nd Gear 1.842, 3rd Gear 1.290, 4th Gear 0.918, 5th Gear 0.775).

**Final Drive Ratio** 4.105

**Flywheel** Minimum weight 7 kg.

**Clutch Diameter** – 184mm

#### **4.4.3 Suspension**

Suspension is free, however mounting points must remain as per Manufacture specifications. Negative Camber is allowed.

#### **4.4.4 Wheels & Tyres**

Racing tires, Slicks or Semi Slicks not permitted. 175 or 185 x 70 x 13 **(Only CEAT tyres will be permitted for Tarmac Circuit, Road Races and Hill Climbs Events)** \* Please contact the SLAS secretariat for information on obtaining tyres.

**Wheel Size 5.5J x 13 (Spacers are strictly prohibited)**

#### **4.4.5 Lighting system**

The original tail lights or lights of similar size have to be fixed in its original mounting points. Modified or individual lights will not be permitted.  
**(Refer G.06/6.4 - Page 7)**

#### **4.4.6 Weight**

MINIMUM CLASS WEIGHT 900 kg (with Driver)

**NOTE:** Current BD, BE series 4-door sedan/hatchback must be subjected to a Pre-scrutinizing to check race worthiness and be certified, this process will be done on two occasions during a year.

If a car/cars are involved in a racing accident and determined by SLAS to be rechecked, the car/cars involved must obtain a fresh Pre-Scrutinizing certificate after completing the repair prior to Racing the vehicle in any race meet.

**\* CARS NOT CERTIFIED BY 2020 WILL NOT BE ALLOWED TO RACE.**

**\* Please contact the SLAS secretariat for information.**

## **4.5 Class Specific Regulations for GROUP N cars up to and including 1500cc**

(One Make Ford Laser/Mazda 323 - Grade B License Holders Only)

### **To be read in conjunction with Group N Regulations**

#### **Body shell and Chassis**

Only BD, BE, BF series 4-door sedan/ hatchback

#### **4.5.1 Engine**

E5 (chain driven single or dual)

**Bore** - 77 mm / Stroke 80 mm / CC 1491

Maximum re-bore allowed is the second oversize specified by the manufacturer(.50) in relation to the original bore, The re-sleeving of the engine is allowed within the conditions as for re-boring and the sleeve material modified. Planning of the cylinder block and the cylinder head will be allowed up to a maximum of 0.50 mm. However the maximum cylinder capacity due to re-boring cannot exceed 1510cc.

#### **Cylinder head Port sizes**

Intake Port Maximum size: 33mm Tolerance: +/- 0.6mm

Exhaust Port Maximum size: 28mm Tolerance: +/- 0.6mm

Valve Spring Thickness and Height is free (Double springs are prohibited)

#### **Compression Ratio**

Increase in Compression Ratio up to a maximum of 9.5:1 Permitted by facing of cylinder head or block only.

#### **Camshaft**

Camshaft must remain as per manufacturer's specifications.

#### **4.5.2 Transmission**

Standard (Ratios 1st Gear 3.416, 2nd Gear 1.842, 3rd Gear 1.290, 4th Gear 0.918, 5th Gear 0.775).

**Final Drive Ratio** 3.850

**Flywheel** Minimum weight 7 kg.

**Clutch Diameter** – 190mm

### 4.5.3 Suspension

Suspension is free, however mounting points must remain as per Manufacture specifications. Negative Camber is allowed.

### 4.5.4 Wheels & Tyres

Racing tires, Slicks or Semi Slicks not permitted. 175 or 185 x 70 x 13 **(Only CEAT tyres will be permitted for Tarmac Circuit, Road Races and Hill Climbs Events)** \* Please contact the SLAS secretariat for information on obtaining tyres.

**Wheel Size 5.5J x 13 (Spacers are strictly prohibited)**

### 4.5.5 Lighting system

The original tail lights or lights of similar size have to be fixed in its original mounting points. Modified or individual lights will not be permitted.  
**(Refer G.06/6.4 - Page 7)**

### 4.5.6 Weight

MINIMUM CLASS WEIGHT 940 kg (with Driver)

**NOTE:** Current BD, BE series 4-door sedan/hatchback must be subjected to a Pre-scrutinizing to check race worthiness and be certified, this process will be done on two occasions during a year.

If a car/cars are involved in a racing accident and determined by SLAS to be rechecked, the car/cars involved must obtain a fresh Pre-Scrutinizing certificate after completing the repair prior to Racing the vehicle in any race meet.

**\* CARS NOT CERTIFIED BY 2020 WILL NOT BE ALLOWED TO RACE.**

**\* Please contact the SLAS secretariat for information.**

## **4.6 Class Specific Regulations for Group A Cars Modified 1000**

(Grade B License Holders Only)

### **4.6.1 DEFINITION**

Large scale series production cars.

### **4.6.2 HOMOLOGATION**

At least 2500 identical body shells of these cars must have been manufactured in 12 consecutive months.

### **4.6.3 NUMBER OF SEATS**

Cars should have two (02) seats minimum in design at original production stage.

### **4.6.4 CUBIC CAPACITY AND WEIGHT**

Maximum engine capacity 1050 cc -725Kgs (with Driver)

### **4.6.5 ENGINE MODIFICATIONS**

All modifications are permitted, as long as a series production engine block and cylinder head of the same series of body shell used is retained and the cubic capacity (cc) does not exceed 1050cc. De-stroking is not permitted.

### **4.6.6 TURBO CHARGED OR SUPER CHARGED**

Engines the capacity of the engine will be deemed to be the measured capacity multiplied by the factor 1.70.

### **4.6.7 ROTARY ENGINE**

The capacity (cc) will be deemed to be equivalent to twice (x2) the volume of the working chamber.

### **4.6.8 BODY PARTS AND GLASS ITEMS**

All body parts and glass items must be retained as per the original car. However, only Polycarbonate (of minimum thickness 4mm) may replace the the side and rear glasses. Removing the headlights, seats, upholstery, dashboard and carpeting is permitted. The holes may be closed using sheet metal or plastic materials, and may be welded, stuck or riveted. Other apertures in the bodywork may be closed, by adhesive tape only. The original mounting points of the tail light/ brake lights have to be retained. The lenses of these lights have to be clean.

Buffers may be removed for Gravel circuit meets and rallies, compulsory for tarmac and hill climbs.

#### **4.6.9 AIR CLEANER**

Air filter element and housing is free.

#### **4.6.10 CHASSIS / BODY SHELL**

No modifications may be made in the manufacturer's design of the series production body shell and/or chassis. Reinforcements, in the form of crash or similar bars inside or outside, are not permitted except for the fitting of a Roll Cage. However, seam welding, strengthening are permitted.

#### **4.6.11 RE-BORING**

Re-boring must not result in increased capacity so as to make the engine pass into a higher class or exceed the limit allowed in class.

#### **4.6.12 Tires**

Tires are free

#### **4.6.13 Weight**

MINIMUM CLASS WEIGHT 725KG (with driver)

## 4.7 Class Specific Regulations for GROUP A cars Mini 7 One Make

(Grade B License Holders Only)

**These rules shall apply to Mini/ Mini clubman cars manufactured up to 2000**

No alternations are allowed on the Engine, Cylinder Head or Gearbox for that model apart from those modifications specifically allowed below

### 4.7.1 ENGINE

All cars must be raced with standard Mini 998 cc, non-Cooper/S engines and Gearbox.

**Standard 998 cc 'A' series or 'A'+ cylinder block is mandatory.**

All '99H' series blocks.

It is permitted to convert a car normally supplied or homologated as a 850 cc to a 998 cc/1275 cc (or vice versa) provided that all the elements that would have had to have been present in the original form of the vehicle according to these regulations are still present after conversion.

**Bore** - 64.58mm x 76.2mm (1040 cc)

Maximum bore size permitted  $64.58 + 1.5\text{mm} = 66.08\text{mm}$

Only the Standard mini 1000cc Cylinder Head must be retained. The Ports of the Original / above mentioned 1000cc Cylinder heads may be enlarged.

#### **Crankshaft**

Any production Mini with standard stroke 76.20 mm permitted.

**Cooper S Crankshafts Part Nos: 12 A 595, 12A1454, BHM 1436 NOT allowed**

**Cams** - FREE

Optimizing valve timing is permitted. Provided the original duplex wheels are retained. **The use of venire adjustments are prohibited.**

**Valves and springs** - Double Valve Springs Permitted.

Inlet 1 1/6th inch dia., Exhaust 1 inch dia.

#### **Pistons and rings**

[minimum of 3 rings] must be of original specification and material and cannot be modified. The pistons can be flush with the block face, but no part of it can protrude beyond the block face. The original / standard piston can only be replaced with unmodified aftermarket pistons.

**Connecting rod** - can only be replaced with part number:

A Series -	2 Nos.	12G123	} Gudgeon Pin
	2 Nos.	12GI26	} Bush type
A+ Series -	2 Nos.	12A1997	} Interference
	2 Nos.	12A1999	} Fi Type

#### 4.7.2 INDUCTION SYSTEM

A single 1.75" / 44.45 mm SU HS6 carb or single 1.75" (HS4/HIF) carburetor. The air filter element free.

#### 4.7.3 EXHAUST SYSTEM

The exhaust system is free.

#### 4.7.4 IGNITION SYSTEM

The low tension switching of the ignition system shall only be with a contact breaker System. The ignition distributor should be as fitted as standard The use of magnetic field electrical breakers will be permitted in place of Platinum electrical breakers. Nos. 25D4 / 45D4 / 49D4 / 59D4.

#### 4.7.5 COOLING

The standard engine driven cooling fan should be retained in original working order.

#### 4.7.6 AIR CLEANER

Air filter element and housing is free.

#### 4.7.7 TRANSMISSION & CLUTCH

The combined weight of the flywheel and clutch assembly [clutch plate and back plate] Should not be less than 5.9kg.

##### **Flywheel**

Permitted is the Cast Iron or Steel one fitted as standard on the A or A+ engines. Reshaping of the cylinder head inlet and exhaust ports and/or valve chambers is allowed.

##### **Prohibited - Aluminum or competition flywheel / racing gears**

##### **Gear Ratios**

Final Drive STD helical cut 3.76 RATIO (pinion 17-teeth and crown wheel 64-teeth). [A+ Series]

The 29-tooth Primary Gear and the 29-tooth Input Gear must remain standard along with the intermediate gear [idler] 37-tooth and must not be interchanged with any other ratios. The intermediate gear must remain standard. [A Series]



The 24-tooth Primary Gear and the 24-tooth Input Gear must remain standard along with the intermediate gear [idler]

31-tooth and must not be interchanged with any other ratios. The intermediate gear must remain standard.

Prohibited - Locked, torque reducing or any form of limited slip diff prohibited. The replacement of any gears from the ain gear cluster and lay gear as fitted to the Mini 1000, which will in any way alter the ratios, is not allowed.

#### **4.7.8 SUSPENSION**

Rear radius arms cannot be lightened or altered.  
The vehicle may be lowered by alteration of cone/doughnut only.

The original shock absorber length, mounting points and supports cannot be changed. Adjustable shock absorbers Allowed. Negative Camber Allowed.

#### **4.7.9 BRAKES**

**Minifins not allowed.**

#### **4.7.10 WHEELS, TYRES & STEERING**

Wheel width and size: up to 6 inches by 10 inches OR 12 inches.

Prohibited - The drilling or grooving of any brake parts /Split-rimmed wheels are prohibited/ No racing slick tyres allowed.

#### **4.7.11 Weight**

MINIMUM CLASS WEIGHT 695 kg (with Driver)

## 4.8 Class Specific Regulations for GROUP H Cars SLH 1600

(One Make HONDA Hatch Back 3 door - Grade B & A License Holders Only)

**These rules should be read in conjunction with GROUP N regulations**

### 4.8.1 Definitions

Manufacturer	- HONDAMOTOR CO., LTD
Engine	- B16A
Cylinder Capacity	- 1,596cc (STD)

### 4.8.2 Engine

Bore	- 81.00MM (0.50mm 2nd Oversize allowed. Max Bore 81.50mm Max CC 1615.774CC)
Stroke	- 77.40MM
Connecting rod	- Steel
Crank Shaft	- Steel
Sleeves	- Cast Iron
Total minimum volume of a Combustion Chamber in the Cylinder head	- 41.3cm
Minimum volume of a combustion Chamber in the cylinder head	- 42.2cm
Minimum height of the cylinder block	- 263mm (to be measured from the center of the line bore of the crank to the top of the deck)
Piston Material	- Aluminum-alloy
Number of Rings	- 3
Distance from wrist pin center Line to highest point of piston crown	- 13.5mm +/- 0.1mm
Distance from Piston at TDC and the gasket plane of the cylinder block	- +3.5mm +/- 0.3mm

Crankshaft Maximum diameter of Big end journals	- 45.0mm
Cylinder Head Minimum Height	- 140.5mm
Thickness of Cylinder Head Gasket	- 0.7mm +/- 0.2mm
Inlet Valve Diameter	- 33mm
Exhaust Valve Diameter	- 28mm

## **VALVE SPRINGS**

### **Inlet**

Number of springs per valve	- 2
Exterior diameter of the springs	- Inner Spring 20.2mm +/-0.2mm Outer Spring 28.9mm +/-0.2mm
Diameter of Spring Wire	- Inner Spring 2.3mm +/- 0.1mm Outer Spring 3.5mm +/- 0.1mm
Number of Spring Coils	- Inner Spring 6.43 Outer Spring 7.74
Maximum Free Length of the Springs	- Inner Spring 36.7mm Outer Spring 40.9mm

### **Exhaust**

Diameter of the manifold exit(s)	- 42.0mm +/- 1.5mm
Number of Springs per Valve	- 1
Exterior Diameter of the Spring	- 29.3mm +/- 0.2mm
Number of Spring Coils	- 6.44
Diameter of Spring Wire	- 3.7mm +/- 0.1mm
Maximum Free Length of the Spring	- 41.95mm

## CAMSHAFTS

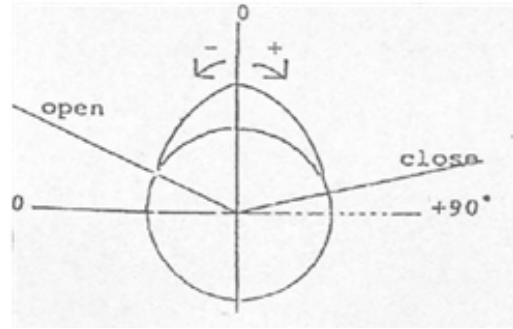
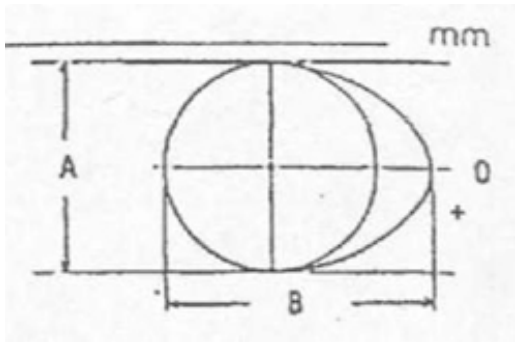

### VTEC CAM Lobe Dimensions

Inlet	"A"	=	29.5mm	+/- 0.2mm
Inlet	"B"	=	36.4mm	+/- 0.3mm
Exhaust	"A"	=	29.5mm	+/- 0.2mm
Exhaust	"B"	=	35.7mm	+/- 0.3mm

### SECONDARY CAM Lobe Dimensions

Inlet	"A"	=	29.5mm	+/- 0.2mm
Inlet	"B"	=	35.0mm	+/- 0.3mm
Exhaust	"A"	=	29.5mm	+/- 0.2mm
Exhaust	"B"	=	34.7mm	+/- 0.3mm

### PRIMARY CAM Lobe Dimensions

Inlet	"A"	=	29.5mm	+/- 0.2mm
Inlet	"B"	=	33.1mm	+/- 0.3mm
Exhaust	"A"	=	29.5mm	+/- 0.2mm
Exhaust	"B"	=	32.8mm	+/- 0.3mm

### 4.8.3 Induction System

Throttle Body bore Diameter	-	60.00mm + 0.2mm
Air filter element and housing	-	Free

### 4.8.4 Exhaust

Exhaust is Free. The Manufacturer's Cast Iron Exhaust Manifold should be retained. (4-2-1)

## 4.8.5 Inlet Manifold, Exhaust Manifold, Inlet & Exhaust Ports Cylinder Head Dimensions

### DRAWINGS / 図解

#### Engine / エンジン

##### I Cylinderhead inlet ports, manifold side

(tolerances on dimensions: -2%, +4%)

シリンダーインテークポート、マニホールド側  
(寸法公差: -2%+4%)

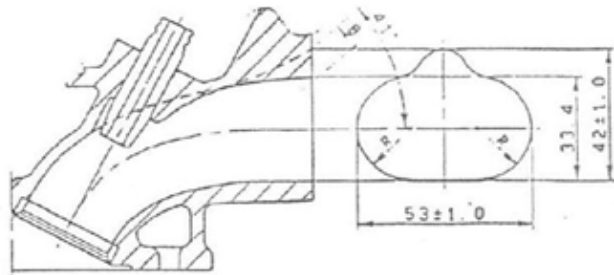

##### II Inlet manifold ports, cylinderhead side

(tolerances on dimensions: -2%, +4%)

インテークマニホールドポート、シリンダーヘッド側  
(寸法公差: -2%+4%)

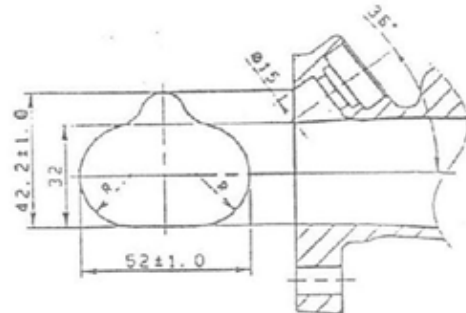

##### III Cylinderhead exhaust ports, manifold

side (tolerances on dimensions: -2%, +4%)

シリンダーヘッドエキゾーストポート、マニホールド側  
(寸法公差: -2%+4%)

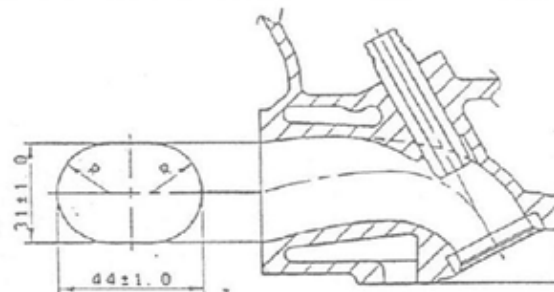

##### IV Exhaust manifold ports, cylinderhead

side (tolerances on dimensions: -2%, +4%)

エキゾーストマニホールドポート、シリンダーヘッド側  
(寸法公差: -2%+4%)



#### 4.8.6 Ignition System

Number of Ignition Coils - 01

#### 4.8.7 Transmission

Clutch Type - Dry single plate

Diameter of Clutch Plate - 220mm +/- 2mm

Flywheel Weight - 7.4kg

LSD - Aftermarket is Permitted

##### Gear Ratio's

1st Gear - 3.230

2nd Gear - 2.105

3rd Gear - 1.458

4th Gear - 1.107

5th Gear - 0.848

Reverse - 3.000

Final Drive - 4.400

#### 4.8.8 Body Parts & Glass Items

All body parts and glass items must be retained. However, only polycarbonate minimum thickness is 4mm may replace the door and side panel glasses which are permanently fixed. Headlights, seats, all interior equipment can be removed or replaced with suitable material. The original mounting position of the tail light/ brake lights has to be retained. The light lenses can't be tinted or discolored. Buffers may be removed for Gravel circuit meets and rallies, compulsory for tarmac and hill climbs.

#### 4.8.9 Others

- The use of Data Loggers allowed.
- Twin or multiple injectors are not allowed.
- Engine Mounts – The Number of Mounts and Material is free.
- Wire Harness and ECU is Free
- Original Fuel Tank mounted in its original position with its original mounting must be retained, use of external fuel pump and regulator is allowed.
- Aftermarket Oil cooler and oil catch tank is allowed.

#### 4.8.10 Tires

Semi Slick Tires (dot-rated) to be used for Tarmac - Circuit meets & Hill climbs, Competition Tires to be used for - Super cross & Rallies.

#### 4.8.11 Weight

MINIMUM CLASS WEIGHT 1075KG (with Driver)

## 4.9 Class Specific Regulation for GROUP H cars SLH 2000

(One Make - Subaru Legacy Grade B License Holders Only)

**These rules should be read in conjunction with GROUP N regulations**

### 4.9.1 MAKE

Subaru

### 4.9.2 MODELS ALLOWED

Legacy- BC, BJ, BF, BD, BG and BK

2,000cc (Non-Turbo)

### 4.9.3 DEFINITIONS

**Manufacturer** : Subaru Corporation/ Fuji Heavy Industries

**Engine permitted** : EJ20 N/A (NATURALLY ASPIRATED)

**Cylinder Capacity** : 1994cc

### 4.9.4 ENGINE

**Bore** - 92.00mm (2nd Oversize allowed 92.5mm)

**Stroke** - 75.00mm

**Con Rod** - Steel

**Crank Shaft** - Steel

**Sleeves** - Cast Iron

**Maximum  
Compression Ratio** - 11.6:1

**Piston** - O.E. Pistons only permitted

**Piston Material** - Aluminum-Alloy

**Re-Sleeving Material** - Free

**Camshaft** - Free

**Valve Spring** - Intake & Exhaust single Valve Spring only  
- Make & Material Free

- Valve Diameter** - Intake not to exceed 36mm  
- Exhaust not to exceed 32mm
- Valve Stem Diameter** - Intake not to exceed 06mm  
- Exhaust not to exceed 6mm
- Valve Overall Length** - Intake not to exceed 104.5mm  
- Exhaust not to exceed 104.6mm
- Valve Seat Angle** - Intake and Exhaust 45 degrees

#### **4.9.5 Induction**

- Throttle Body bore Diameter - 66.00mm
- Air filter element and housing - Free

#### **4.9.6 Transmission**

5 speed manual, All Wheel Drive

**Final Drive** - 4.44 or 4.11

**Clutch, Flywheel, LSD** - Free

#### **4.9.7 Electrical's, Wire harness, ECU, Fuel System - Free**

#### **4.9.8 Tires**

Semi Slick Tires (dot-rated) to be used for Tarmac - Circuit meets & Hill climbs, Competition Tires to be used for - Super cross & Rallies.

#### **4.9.9 Weight**

MINIMUM CLASS WEIGHT 1175KG (with Driver)



## **4.10 Class Specific Regulations for Group GT Cars up to 3500cc**

(Grade A License Holders Only)

### **4.10.1 DEFINITION**

Large scale series production cars.

### **4.10.2 HOMOLOGATION**

At least 2500 identical body shells of these cars must have been manufactured in 12 consecutive months.

### **4.10.3 NUMBER OF SEATS**

Cars must have four (04) seats minimum whilst being manufactured.

### **4.10.4 WEIGHT**

Up to 3500 cc - 1350Kgs (with the Driver)

### **4.10.5 ENGINE MODIFICATIONS**

All modifications are permitted as long as a series production engine block is retained and the cubic capacity (cc) does not exceed the class limit. The Engine could be interchanged with an earlier/later model of the same series. However For Mitsubishi Lancer/ Cedia Cars that are been upgraded to a 4WD from a 2 Wheel Driver an Engine change will be permitted only to a 4G63 (Upgrade up to Evo 9) or a 4B11 (Upgrade to Evo 10).

Oil cooler is free.

For Turbocharged or Supercharged engines the capacity of the engine will be deemed to be the measured capacity multiplied by the factor 1.70.

For Rotary engine, the capacity (cc) will be deemed to be equivalent to twice (x2) the volume of the working chamber.

### **4.10.6 BODYSHELL/ CHASSIS**

No modifications may be made to the manufacturer's design of the series production body shell and / or chassis. However, the only modifications permitted to the body shell would be - seam welding, strengthening, mounting roll cage and that which is necessary to convert or upgrade a vehicle from a two wheel drive to a four wheel drive and in addition front nose panel could modified to be detachable.

### **4.10.7 AIR CLEANER**

Air filter element and housing is free.

#### **4.10.8 BODY PARTS and GLASS ITEMS**

All body parts and glass items must be retained. However, only Polycarbonate door windows (of minimum thickness 4mm) may be replaced, (front and rear windscreens to remain glass).

The tail lights and stop lights have to be retained and be in operating condition. Headlights/ front lights, seats, all interior equipment can be removed or replaced. Head lights may be covered with suitable material. Buffers may be removed for Gravel meets and rallies only, (bumpers are compulsory for tarmac). Use of fiberglass on Mud Guards, Fenders and Bumpers are permitted, as an option to the original parts. (All Other materials Prohibited). Hidden lurk bars behind the front and rear bumpers is strictly prohibited. Also aero dynamical devices will be allowed as long as the body shape does not change. Trim strips and body moldings may be removed.

#### **4.10.9 RE-BORING**

Re-boring must not result in increased capacity so as to make the engine pass into a higher class or exceed the limit allowed by these regulations.

#### **4.10.10 TURBOCHARGED OR SUPERCHARGED CARS UP TO 3500 CC**

The series production turbocharger or supercharger must be retained in the original position as per the standard engine. Replacing internals or housings or any other part among series production or after market turbochargers or superchargers are prohibited. Any modification/ s to the original turbo charger or its components is strictly prohibited (Including waste gate). External waste gates are prohibited.

**Refer Separate attachment Number SLGT – TR 1 for Specification on Turbo chargers pertaining to 4G63, 4B11, EJ 20 engines. (The details given below APG-GT-01/2 will be final.)**

#### **4.10.11 RESTRICTOR**

All turbocharged or supercharged cars must be fitted with a 34mm restrictor fixed to the compressor housing. The 34 mm area should be maintained for a minimum of 3 mm. All the air necessary for feeding the engine must pass through the restrictor.

The maximum internal diameter of the restrictor is 34 mm, maintained for a minimum distance of 3 mm measured downstream of a plane perpendicular to the rotational axis situated at a maximum of 50 mm upstream of a plane passing through the most upstream extremities of the wheel blades, This diameter must be complied regardless of the temperature conditions. This rule will apply to all events except for hill climbs.

The external diameter of the restrictor at its narrowest point, must be less than 40 mm, and must be maintained over a distance of 5 mm to each side.

The mounting of the restrictor onto the turbocharger must be carried out in such a way that two screws have to be entirely removed from the body of the compressor, or from the restrictor in order to detach the restrictor from the compressor. Attachments by means of needle screws are not authorized.

For the installation of this restrictor it is permitted to remove material from the compressor housing, and add to it, for the sole purpose of attaching the restrictor onto the compressor housing. The head of the screws must be pierced so that they can be sealed.

The restrictor must be made from a single material and may be pierced solely for the purpose of mounting and sealing which must be carried out between the mounting screws, between the restrictor (or the restrictor-compressor housing attachments), the compressor housing (or the housing/flange attachment) and the turbine housing (or the housing-flange attachment). In case of an engine with two parallel compressors, each compressor must be limited by a restrictor with a maximum internal diameter of 24.0 mm and a maximum external diameter of 30 mm in the conditions set out above.

Normal aspirated engines with a CC of more than 2000 should have a restrictor, with an internal diameter of 37 mm (in the case of one restrictor) and 27mm in the case of two (02) restrictors.

#### **4.10.12 RACE WORTHINESS AND SAFETY**

Competitors must ensure that the competition vehicle is race worthy and safe. The interpretation of this clause will lie with the Chief scrutiner / Stewards of the meet.

#### **4.10.13 TIRES**

Tires are Free for Gravel, Rallies and Hill Climbs, However a one make Tire has been approved made compulsory for all Circuit (Tarmac) Race meets. TIRES permitted (Under Dry Conditions) for qualifying and Racing will be as follows.

HANKOOK VENTUS Z214  
SIZE 245/40ZR17  
COMPOUND (C51)

In case of Wet weather, the organizing Club has to declare that the track is Wet in order for Wet tyres to be used prior to a qualifying session or race.

#### **4.10.14 FUEL TANK**

The fuel tank should be mounted in the original manufactures mounting position.

#### **4.10.15 Exhaust**

Exhaust is free.

**4.10.16 SL-GT up to 3500CC TURBO MEASUREMENTS – Maximum Dimensions.APG-GT-01**

SLGT Turbo regulation for 4G63 engine, Maximum Measurements.

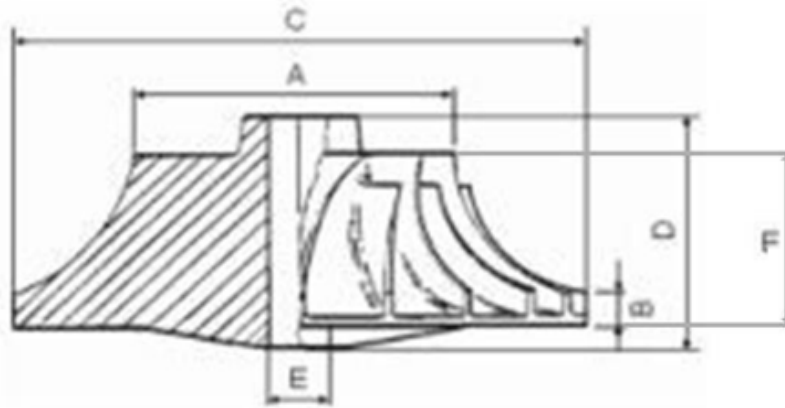

<b>Impeller</b>	<b>Diagram</b>	<b>SPEC</b>
Number of blades		6 taller+ 6 Short
A. Blade Upper diameter (taken as Inner diameter of the impellor housing at the narrowest)	Diagram I1	50mm
B. Blade outer height	Diagram I2	5.6mm
C. Impeller Diameter	Diagram I3	68mm
D. Impeller height	Diagram I4	31.5mm
E. Impeller side Shaft Diameter	Diagram I 5	6.6mm
F. Height of blades Tall Short	Diagram I6	22mm 16.4mm
<b>Turbine</b>		
Number of blades		12
A. Blade top diameter	Diagram E1	50.38mm
B. Blade height	Diagram E2	20.5mm
C. Blade bottom Diameter	Diagram E3	56.5mm
D. Turbine height	Diagram E4	25mm
E. Shaft Diameter	Diagram E5	9.2mm
<b>GENERAL</b>		
Bearing	Gen 1	Bush
Blades/Vanes		No Variable Vanes

**4.10.17 SL-GT up to 3500CC TURBO MEASUREMENTS – Maximum Dimensions. APG-GT-02**

SLGT Turbo regulation for 4B11 engine, Maximum Measurements.

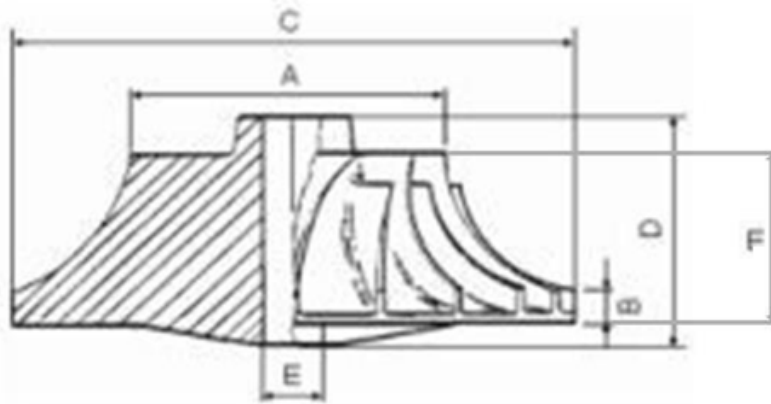

<b>Impeller</b>	<b>Diagram</b>	<b>4B11 engine</b>
Number of blades		6 taller+ 6 Short
A. Blade Upper diameter (taken as Inner diameter of the impellor housing at the narrowest)	Diagram I1	48mm
B. Blade outer height	Diagram I2	
C. Impeller Diameter	Diagram I3	68mm
D. Impeller height	Diagram I4	
E. Impeller side Shaft Diameter	Diagram I 5	
F. Height of blades Tall Short	Diagram I6	
<b>Turbine</b>		
Number of blades		12
A. Blade top diameter	Diagram E1	49.5mm
B. Blade height	Diagram E2	
C. Blade bottom Diameter	Diagram E3	56mm
D. Turbine height	Diagram E4	
E. Shaft Diameter	Diagram E5	
<b>GENERAL</b>		
Bearing	Gen 1	Bush
Blades/Vanes		No Variable Vanes

## **4.11 Class Specific Regulations for Group T&J**

(Grade B License Holders Only)

Specific Rules & Regulations for SL-T&J Double and Single Cabs, SUVs and other 4-wheel drive T & J vehicles

### **4.11.1 DEFINITION**

Double Cabs, Single Cabs, Special Utility Vehicles and other four-wheel drive vehicles.

### **4.11.2 MODIFICATION**

Engine, Gearbox, Air Intake, Suspension and Braking System is permitted, provided the engine is originally designed for/ or derived from any automobile of any make or model.

### **4.11.3 EXCLUSIONS**

Motor cycle/boat/aircraft engines is not allowed.

Turbo, Rotary and super charged engines, are allowed, provided that it does not exceed the class limit.

**Number of Seats:** Minimum 02 front mounted seats when being manufactured.

### **4.11.4 Safety Regulations – should conform to General Specifications**

### **4.11.5 MODIFICATIONS BODY**

All modifications permitted. However, any vehicle considered unsafe or not race worthy as deemed by the Chief Scrutinizer/ Stewards of the Meet or the Organizing Committee will not be permitted to participate.

### **4.11.6 TIRES**

Tires are free

## **4.12 Class Specific Regulations for GROUP S cars up to and Including 1500cc**

(Grade B & A License Holders Only)

### **4.12.1 HOMOLOGATION**

Any Body shell/Chassis

### **4.12.2 MODIFICATION**

Engine, Gearbox, Air Intake, Suspension and Braking System is permitted, provided the engine is originally designed for/ or derived from any automobile of any make or model.

### **4.12.3 EXCLUSIONS**

Motor cycle/boat/aircraft engines is not allowed.

Turbo, Rotary and super charged engines, are allowed, provided that it does not exceed the class limit.

**Number of Seats:** Minimum 02 front mounted seats when being manufactured.

**Maximum Cubic Capacity up to and including:** 1500 cc with De-stroked engines Minimum weight to be 1025KG (with driver)

**Maximum Cubic Capacity up to and including:** 1500 cc – with Non De-Stroke Engines Minimum weight to be 800KG (with driver)

**Maximum Cubic Capacity up to and including:** 1350 cc - Minimum weight to be 700KG (with driver)

The original tail lights or lights of similar size have to be fixed in its original mounting points. Modified or individual lights will not be permitted

### **4.12.4 Safety Regulations should conform to General Specifications**

### **4.12.5 MODIFICATIONS BODY**

All modifications permitted. However, any vehicle considered unsafe or not race worthy as deemed by the Chief Scrutinizer/ Stewards of the Meet or the Organizing Committee will not be permitted to participate.

### **4.12.6 TIRES**

Tires are free.

## **SECTION 5 FORMULA CARS**

### **5.1 Formula McLarens 1300cc**

Vehicle specifications are as per owner's manual (engine and chassis)

### **5.2 Modified Formula Cars up to 1665cc**

Type and make of engine and chassis are free.

### **5.3 Specific Regulations for Formula Ford 1600**

#### **GENERAL**

As with all regulations, "UNLESS IT SAYS YOU CAN DO IT. YOU CANNOT".

#### **5.3.1 DESCRIPTION**

Four wheel, single seater racing car, as defined for Formula 3 (1985) and these regulations fitted with a Ford 1600cc GT "Kent" Engine.

#### **5.3.2 SAFETY**

These regulations are based on the current RACMSA Yearbook (Blue Book). All relevant end current RACMSA regulations apply. See Appendix 'A' for some of the more specific regulations.

#### **5.3.3 CHASSIS**

- (a) The chassis must be of tubular steel construction with no stress bearing panels except bulkhead and undertray, curvature of the undertray must not exceed 2.54cm. The undertray/floor (E 13.2.4) extends from the bulkhead forward of the pedals to the bulkhead between the fuel tank and the engine. Monocoque chassis construction is prohibited. Stress bearing panels are defined as, sheet metal affixed to the frame by welding or bonding or by rivets, bolts or screws which have centres closer than 15.25cm. Bodywork must not be used as stress bearing panels. The use of stabilised materials, composite materials using carbon and/or Kevlar reinforcement is prohibited.
  
- (b) Cars built after 1.1.87 and before 1.1.95 The internal cross section area of the cockpit from the driver's feet to behind his seat, shall nowhere be less than 700 cm<sup>2</sup> and a minimum width must be 25cm over the whole length of the cockpit. The only intrusion permitted into the cross sectional area being the steering column.
  
- (c) Cars built after 1.1.95 The free internal cross section of the cockpit from the soles of the driver's feet to behind his seat shall at no point be less than 700cm<sup>2</sup>. The only thing which may encroach on this area is the steering column. A free vertical section of minimum 25cm width maintained to a minimum height of 25cm with corners of maximum 5cm radius must be maintained over the whole length of the cockpit with the steering wheel removed. The driver normally seated in his driving position with the seat belts fastened and the steering wheel in place must be able to raise both legs together such that his knees reach the plane of the steering wheel in the rearwards direction: this action must not be obstructed by any part of the car.



- (d) Cars built after 1.1.87 The soles of the feet of the driver, seated in the normal driving position and with his feet on the pedals in the inoperative position, shall not be situated to the fore of the vertical plane passing through the centre line of the front wheels.
- (e) No engine oil or water tubes are permitted within the cockpit.
- (f) Cars built after 1.1.95 -The chassis must include an impact-absorbing structure fitted ahead of the front bulkhead of the tubular steel frame. This structure must be independent of the bodywork and must be solidly fixed to the extremities of the bulkhead (i.e. with bolts requiring tools for removal). It must constitute a box of 30cm minimum length, 15cm minimum height in any vertical section and 400cm<sup>2</sup> minimum total cross section. It must be metallic using honeycomb sandwich construction with a panel thickness of 15mm minimum. It is recommended, but not mandatory, that this safety feature is fitted to older cars.
- (h) Cars built after 1.1.96: Must be built with a LATERAL PROTECTION STRUCTURE, defined as continuous panels whose projection on a vertical plane parallel to the longitudinal axis of the car shall be at least 15cm high, shall extend on either side of the car, at a minimum distance of 55cm from the car's longitudinal centre line between at least the transverse planes passing through the fuel tank rear face and the frontal extremity of the minimum cockpit opening, and at a minimum distance of 35cm from the car's longitudinal centre line between at least the transversal planes passing through the above extremity and the front rollover bar hoop. These panels shall be made from a composite material of 30cm<sup>2</sup> minimum cross section with a honeycomb core in metal giving adequate resistance to compression. The external skins shall be of aluminium alloy of a minimum thickness of 0.5mm or made up of another assembly of materials of equivalent efficiency. The panels must be securely attached to the bottom and at the upper extremity to the main structure of the car in such a manner as to ensure absorption of a lateral impact. The radiators may play the role of protective panels or of transversal struts. The periphery of the bodywork covering the Lateral Protection Structure, when viewed from below, must be curved upwards with a minimum radius of 5cm, and a maximum radius of 7cm with the exception of air entry and exit openings into the Lateral Protection Structure. The floor of the side pod must reflect the plan of the upper surface. The floor is to be in the same plane as the undertray in both directions, i.e. transverse and longitudinal, subject to all points being within 2.54cm of any flat plane situated under the car (see Art 3.1).

#### **5.3.4 BODYWORK**

See table of single seater dimensions. (Appendix "B"). The use of composite materials using carbon and/or Kevlar reinforcement is prohibited. Bodywork is not required behind the vertical plane taken through the front of the topmost portion of the roll over structure. If bodywork is used it must conform with the following regulation.

- (a) Any device designed to augment aerodynamically the downthrust on the vehicle is prohibited, as are aerofoils, nose fins or spoilers of any type.
- (b) For cars built after 1.1.87 The engine cover must not extend rearwards past the rearmost point of the gearbox housing (no gearbox extensions permitted). The shape of the cover must not include any reflex curves and no flat surfaces are permitted within 15° of the horizontal.
- (c) For cars built after 1.1.87 The lower rear bodywork (located below the wheel centre line) is only permitted alongside and beneath the engine and can only extend from behind the cockpit to a line drawn through the rear axis. The incorporation of suspension or other fairings in this bodywork or separately is prohibited.
- (d) It is not permitted to construct any suspension member in the form of an aerofoil or to incorporate a spoiler in the construction of any suspension member.
- (e) All cars must have at least two mirrors mounted so that the driver has visibility on both sides of the car (minimum surface area of each one: 55cm<sup>2</sup>.)
- (f) For cars built after 1.1.95 Cockpit opening: The opening giving access to the cockpit must allow a designated horizontal template to be inserted vertically into the cockpit (not considering the steering wheel) down to 25mm lower than the lowest point of the cockpit opening. This template is defined by dimensions J,K,L in Appendix "B".
- (g) See also Lateral Protection Structures.

### **5.3.5 ENGINE**

#### **GENERAL**

- (a) Engines will be mounted upright, and aligned fore and aft in the chassis.
- (b) The addition of any material be it metal, plastic or composite etc. by any means be it welding, bonding, encapsulation or encasement to any component is prohibited. However, specific repair of the mounting points of the cylinder block to the transmission or chassis are allowed, whilst other casting repairs may be allowed with prior written approval of the Technical Commissioner responsible for the Formula.
- (c) Balancing of reciprocating and rotating parts is permitted only by removal of metal from locations so provided by the manufacturer.
- (d) Pump, fan and generator drive pulleys and their retention bolts, washers and belts are free.

- (e) Mechanical tachometer drives may be fitted.
- (f) Generators are optional.
- (g) The use of non-standard replacement fasteners, nuts, bolts, screws, studs and washers which are not connected with, or which do not support, any moving parts of the engine or its compulsorily retained accessories is permitted. Freedom granted to any fastener does not allow for freedom to move items relative to each other. For components that are granted the freedom for the fitment of a key or dowel, then material may be removed to allow the fitting of the key or dowel. Only one hole or keyway per component is allowed.
- (h) The use of thread locking compounds is permitted.
- (i) Gaskets are free except for the cylinder head, intake and exhaust system gaskets which must be standard Ford manufacture for the engine, and inlet manifold to cylinder head gasket which must be of approximate production thickness (see 5.2e).
- (j) Any process of cleaning may be used on any component providing the surface finish, which must remain standard, is not affected.
- (k) Forced induction is prohibited. Ram Air generated by the forward motion of the car is not considered as forced induction.
- (l) The exterior surfaces only (of the complete engine assembly) of ferrous parts and the exterior surface of the aluminium Rocker Cover may be protected by paint or similar means. No internal component or surface may be coated by any protective finish. Other Ford produced aluminium components may be protected only on their external surfaces by a transparent clear varnish, or similar.
- (m) Part numbers quoted were correct at the time the regulations were drafted. However, as with all companies, the Ford Motor Company Limited reserve the right to make changes to components for reliability or other reasons. Consequently the part numbers quoted may be superseded by later released parts. Full Ford part numbers do not necessarily appear on all parts.

### **5.3.6 PERMITTED ENGINE**

The only permitted engine is the Ford 1600 GT "Kent" (also referred to as Mark II Escort 1600 "Sport") with a nominal bore 81 mm and stroke 77.6mm. Production tolerances are permitted providing the total swept volume does not exceed 1600cc.

### **5.3.7 INDUCTION**

- (a) The air cleaner may be removed or replaced and a trumpet fitted.

- (b) Carburettor Type: Weber 32/36 DGV and DGAV (from 1600 GT "Kent" or 2000 SOHC NE engine). Number on engine 1 Number of Main Venturi 2 Maximum dia. of Main Venturi 26.0/27.0mm Maximum dia. of carb outlet to inlet manifold 32.0/36.0mm.
- (c) It is permitted to change jets, open both throttles together, remove cold start devices and diffuser bar, fit internal and external anti-surge pipes, remove seals on emission control carburettors. No other modifications are permitted, chokes must remain standard and no polishing or reprofiling is permitted. Any means of reducing intake air temperature is prohibited. Any form of water injection is prohibited.
- (d) Inlet manifold: standard Ford production inlet manifold for 1600 GT "Kent" engine. The carburettor seat face may be machined to horizontal in the fore and aft plane. The water passage must remain intact but may be blanked off or plugged. The manifold may be machined externally to clear the throttle mechanism in the use of both throttles being opened together.
- e) Carburettor to inlet manifold gasket Thickness 5.7mm  $\pm$  0.35mm Inlet manifold to cylinder head Thickness 0.86mm (max)

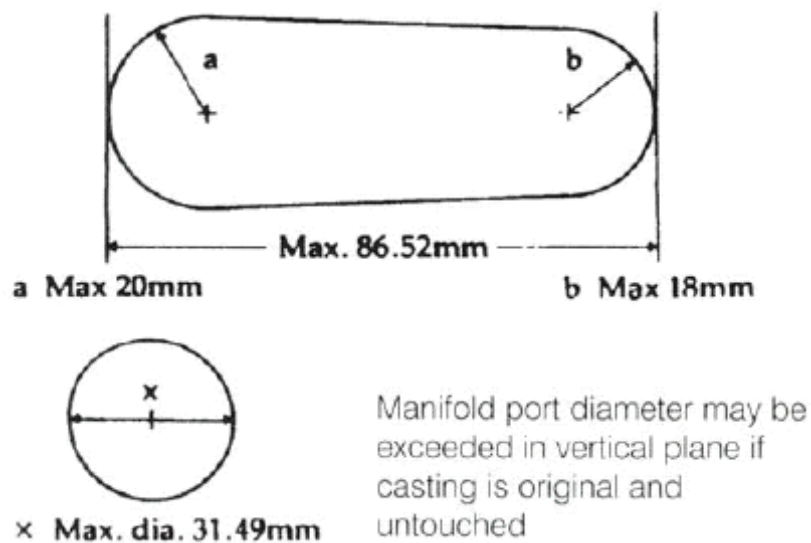

### 5.3.8 EXHAUST SYSTEM

- (a) The exhaust system and manifold are free, within Vehicle Regulations.
- (b) A mandatory silencer, Ford Part No. 9095317 (or old unit 9094277) must be fitted.

### 5.3.9 CYLINDER BLOCK

- (a) It is permitted, as means of repair, to replace damaged cylinder bores with cast iron cylinder liners, all to standard dimensions.

- (b) Localised machining of the cylinder block is permitted to allow fitting of the dry sump system.
- (c) The crankcase breather may be altered or removed, but all breathers must discharge into a catch tank.
- (d) May be machined to maintain deck height.

### **5.3.10 CYLINDER HEAD (INCLUDING VALVES AND VALVE GEAR)**

- (a) Non-standard rocker covers are permitted providing they in no way improve the performance of the engine. Water passages are not permitted in rocker covers.
- (b) Standard valve spring retainers must be used, only single valve springs are permitted. Shims are permitted, otherwise valve springs are free.
- (c) Push-rods, rockers, tappets, pedestals and shafts must remain standard except that recontouring of the valve stem contact pad on the rocker arm is permitted providing the maximum specified lift at the spring cap is not exceeded. Rocker shaft springs are free.
- (d) Maximum permitted lift at the spring cap with zero tappet clearance: inlet 9.042mm, exhaust 9.093mm. Maximum permitted lift at the top of the push rod: inlet 5.917mm, exhaust 5.943mm.
- (e) Valves must remain standard, no reprofiling or polishing is permitted. The original 45° seat angle must be maintained. Distance apart at centres 39.12 ± 0.5mm. Maximum face diameter, inlet 39.62mm; exhaust 34.00mm.

Overall length inlet 110.92 ± 0.5mm. Overall length exhaust 110.61 ± 0.5mm. Valve stem seals are optional.

- (f) It is permissible to reshape inlet and exhaust ports by removal of metal within limits. Addition of material in any form is prohibited. Maximum port diameter at manifold face: inlet 36.12mm, exhaust 29.41mm. Inlet and exhaust port diameter may be exceeded if the original casting is visible and untouched at the gasket face.
- (g) It is permitted, as means of repair, to replace damaged valve guides and valve seats by replacement valve guides and valve seat inserts, all to standard dimensions.

### **5.3.11 COMPRESSION RATIO**

- (a) The maximum compression ratio will be controlled as follows:  
(Minimum combustion volume in piston 41cc (with piston at TDC in cylinder and no account taken of volume down from the crown to the top piston ring).

- (ii). Standard Ford cylinder head gasket Part No. 781M 6051 AA / 931M 6051 AA minimum. compressed thickness 0.85mm, minimum diameter of cylinder head aperture 82.50mm.
- (iii). Pistons must not protrude above the cylinder block face at TDC. The cylinder block surface may be machined.
- (iv). Maximum permitted protrusion of the valves into the combustion chamber 1.2mm.

### 5.3.12 CAMSHAFT

- (a) The only permitted camshaft is the Ford production camshaft for the 1600 GT "Kent" engine.
- (b) The camshaft must remain entirely unmodified. It must be fully manufactured and ground to the Ford Motor Company profile. It is prohibited to grind from blanks, regrind or reprofile. Tuftriding or Parkerising is permitted. Shot peening, shot blasting or polishing are prohibited. Offset dowels are permitted.
- (c) The cam profile is defined by determination of lift (L-l) against a flat footed follower at various angles ( $\theta$ ). Maximum lift at all points on the camshaft must not be exceeded.

**Standard Ford tolerances apply to the following camshaft drawing:**

Dimension	Symmetrical	
	Inlet	Exhaust
DM (max)	33.60mm	33.65mm
Dm	27.78mm	28.15mm
Lift at 0°	5.37mm	5.89mm
Lift at 5°	5.81mm	5.85mm
Lift at 10°	5.64mm	5.67mm
Lift at 15°	5.38mm	5.41mm
Lift at 20°	5.00mm	5.03mm
Lift at 30°	4.01mm	4.04mm
Lift at 40°	2.69mm	2.77mm
Lift at 60°	0.46mm	0.61mm
Lift at 90°	0.05mm	0.20mm

Angle between major axes of inlet and exhaust cams:  
109°.

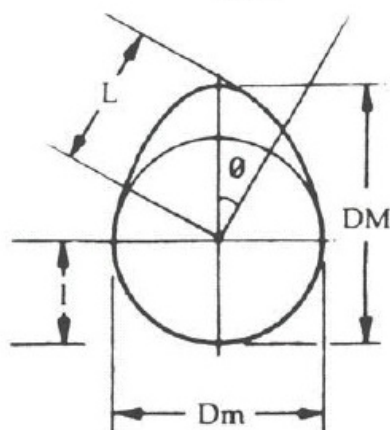

### **5.3.13 PISTONS**

- (a) Pistons must be standard Ford production pistons for the 1600cc engine, unmodified in any way except for balancing and as detailed.
- (b) All three piston rings must be fitted, piston rings must be standard production or similar replacements, i.e. the compression rings must be one piece, with conventional plain gaps, chromium plating of the top ring is optional, the oil control rings must be either single piece twin land type or apex three piece (two rails and an expander). Molybdenum faced top compression rings are permitted.
- (c) Localised machining of the bowl including valve relief and gudgeon pin bosses of the piston to achieve volumetric and weight balance and minimum weight is permitted. Minimum weight complete with piston rings and gudgeon pin: 520gm, weight of gudgeon pin: 115 ± 2.0gm.

### **5.3.14 CONNECTING RODS**

- (a) Connecting rods must be standard Ford Part No. 2737E 6200 B. Machining is permitted to remove metal from the balancing bosses on the big-end cap and at the little end to achieve balance only. Polishing is prohibited. Minimum weight (including bolts and small end bearing) 640gm.

### **5.3.15 CRANKSHAFT**

- (a) A standard crankshaft must be used. Spot machining to achieve balance is permitted. Tuffriding, shot peening and shot blasting are permitted. Polishing is prohibited. Crankshaft minimum weight: 11.2kg.
- (b) Crankshaft pulley is free as is tooth belt drive.
- (c) It is not permitted to alter the number of bearings or fit bearings of less than standard production width.
- (d) Standard oversize and undersize bearings are permitted.
- (e) The rear main journal may be fillet rolled in the radius.

### **5.3.16 FLYWHEEL AND CLUTCH**

- (a) The flywheel and clutch assembly must be standard components. To achieve minimum weight and balance, material may be removed from the originally machined surfaces, rim/flange etc. For rectification, the clutch mating face may be resurfaced. Cast surfaces must remain in original condition. It is permitted to use a similar pattern replacement clutch (i.e. conventional single diaphragm spring) driven plate with shock absorber springs. Organic friction material only is permitted. Racing clutches are prohibited.

- (b) Flywheel bolts are free and locating dowels are permitted.
- (c) It is permitted to secure the starter ring to the flywheel.
- (d) Flywheel and clutch assembly minimum permitted weight: 13.16kg. (including all flywheel and crankshaft mounting bolts).

### **5.3.17 LUBRICATION SYSTEMS**

The lubrication system, external to the engine, is free. Existing standard production oilways, linings or oil grooves may be enlarged or reduced, but no additional ones are permitted. Standard friction surfaces must remain unchanged. Dry sump is permitted, oil coolers are free.

### **5.3.18 COOLING SYSTEM**

- (a) A liquid cooling system is mandatory but radiator and water pump are free.
- (b) The radiator, if housed in or incorporating a cool air scoop or deflector, must comply with bodywork regulations.

### **5.3.19 FUEL PUMP**

- (a) Only the standard mechanical fuel pump for the engine is permitted.
- (b) Fuel pipes are free. Fuel cooling radiators are permitted, within safety regulations, but must be mounted within the main chassis frame.

### **5.3.20 DISTRIBUTOR**

- (a) Distributors are free providing they retain the original drive and location.
- (b) The distributor is defined as the component which triggers the LT current and distributes the HT ignition current. The ignition timing may only be varied by vacuum and/or mechanical means. It is prohibited to use any other method or component to trigger, distribute or time the ignition.
- (c) It is permitted to mount a simple indicating pointer to the engine to facilitate the timing of the distributor with respect to the crankshaft/flywheel.

### **5.3.21 SUSPENSION**

- a). The following parts must be of alloy steel or other ferrous material: wishbones, rockers, push and/or pull rods. All other stress bearing components must be metallic with no composite materials allowed. It is permitted to incorporate suspension mounting points on the engine and transmission assembly.



- (b) Active suspensions are prohibited, as is any system which allows control of the flexibility of the suspension springs, shock absorption and trim height when the car is moving.
- (c) Anti-roll bars for front and/or rear suspension may be capable of manual adjustment by the driver when seated in the car.
- (d) Simple ovalised tubes which have the same section top and bottom are not considered to be an aerofoil.

#### **5.3.22 BRAKES**

Only brake discs made predominantly from Ferrous material are permitted. Calipers must be of Ferrous material with a maximum of two working cylinders per calmer. Brake pad materials, including carbon metallic, are free.

#### **5.3.23 SHOCK ABSORBERS**

Light alloy casings and/or separate reservoirs for fluid/gas are prohibited, otherwise free. Any form of active damping is prohibited. Any method of altering the damper performance by the driver whilst seated in the car is prohibited. The shock absorber casing is defined as the item which contains the piston, fluid/gas, and moving parts which control the damping action.

#### **5.3.24 STEERING**

The steering must consist of a mechanical link between the driver and the wheels, rear wheel steering prohibited, otherwise free.

#### **5.3.25 WHEELS & TYRES**

- (a) 13 inch diameter steel wheels with a maximum rim width of 5.5 inch are the only wheels permitted. They must be of standard manufacture but the off-set may be altered. (It is recommended that weekly checks for cracks be carried out and that the wheels be replaced twice a year).
- (b) The only tyres permitted are those listed in the Sporting Regulations for the event. Minimum tread depth 1mm at the start of each practice session and race.
- (c) Tyre warmers are not permitted. Tyre covers whose only function is to protect the tyre in the paddock area are allowed. Tyre warmers found at the circuit will be judged to be available for use.

#### **5.3.26 TRANSMISSION**

- (a) The gearbox must contain not more than four forward gears and include an operable reverse gear, capable of being engaged by the driver whilst normally seated. The ratios are free.

- (b) Rear wheel drive only is permitted.
- (c) Final drive ratio is free.
- (d) Torque biasing, limited slip and locked differentials are prohibited. Non-ferrous differential components prohibited.
- e). Gear change must be manual in operation. The gearchange must use the conventional 'H' pattern gearchange gate. Any gear change mechanism that only allows sequential selection of gears is not permitted.
- (f) The only position for the main gear cluster will be wholly behind the rear axle output shaft centre line, and in line with the crankshaft centre line. Transverse, vertical, or other non in-line configuration will not be allowed.

### **5.3.27 FUEL SYSTEM**

- (a) Tanks outside the chassis frame must comply with FIA Spec Ft3.
- (b) Inboard tanks, covered externally with a fireproof coating, are acceptable for events of less than 70km.
- (c) Protection must at all times comply with J20.1.1 and E 13.2.3 (Bulkheads). A metal tank coated with GRP does not comply.
- (d) Maximum capacity 41 litres unless carried in FIA spec FT3 tank or better.
- (e) No fuel can be used which exceeds BS 7800: 1992 (Super Unleaded), or BS 4040 (Premium Leaded) or equivalents outside the UK. A mixture of fuels is not allowed. Event regulations are allowed to specify a single source fuel which meets these minimum standards, but do not exceed it.
- (f) At the end of practice and the race at least 3 litres of fuel from the tank of the competing car must be available to the scrutineers for analysis. Compliance with minimum weight for the car will be taken before the fuel is removed.

### **5.3.28 STARTING**

- (a) Compulsory electric starter with electrical source of energy carried on board the car, and able to be controlled by the driver when normally in his seat.
- (b) A supplementary external source of energy temporarily connected to the car may be used to start the engine whilst in the pit area.

### **5.3.29 WEIGHT**

Minimum car weight at any time during the competition 420Kg

### **5.3.30 ENGINE SEALING**

All engines should have provision for scrutineer's wire seals. 1/16 inch dia. holes predrilled in readily accessible locations on installed engines must be available. Failure to comply renders the entrant liable to a fine.

- (a) Sump - two holes through the cylinder block/ sump joint flange, one either side of the engine.
- (b) Timing Cover - at least two retaining screw heads must be cross drilled.
- (c) Rocker Cover - at least two retaining screw heads must be cross drilled.
- (d) Inlet Manifold - at least two retaining bolt heads to the cylinder head must be cross drilled.
- (e) Carburettor - at least two retaining nuts to the cylinder head must be cross drilled.
- (f) Bellhousing - at least two retaining bolts to the engine must be cross drilled to enable clutch and flywheel to be adequately sealed, OR competitors must be prepared to remove either engine or transmission to enable sealing of clutch and flywheel in which case at least two clutch cover retaining bolts must be cross drilled. Failure to comply renders the engine ineligible.

### **5.3.31 MISCELLANEOUS**

- (a) Use of titanium, high strength composites, and similar materials is prohibited.
- (b) Electronic dashboards and Data logging equipment are allowed subject to them having no influence whatsoever on the behaviour of the car during competition. All information obtained from any Data logging or storage equipment shall be made freely available to the Scrutineer on request.
- (c) Competitors are reminded that only modifications or additions specifically covered by these regulations are permitted. Engine components not covered by these regulations must remain completely standard and unmodified. In cases of dispute on engines, reference will be made to Ford Motor Company Limited drawings.
- d). Vehicles defined in these regulations are required to comply with the section of the RAC MSA yearbook covering General Vehicle and Race Vehicle which apply to single seater racing cars, a summary of which is given in

## 5.4 FORMULA FORD 1600 - PRE-1974

### 5.4.1 DESCRIPTION

Single seater racing cars complying with current Formula Ford 1600 regulations, and these regulations, manufactured prior to 1st January 1974.

### 5.4.2 CHASSIS

The chassis specification must remain fundamentally unaltered from original manufacture. Wheelbase, Track, and pick-up points must remain to manufacturers specification.

### 5.4.3 PERMITTED MODIFICATIONS

To current Formula Ford-1600 regulations.

- (a) Any modification of which the primary purpose is safety or driver comfort.
- (b) Bodywork is free within FF-1600 dimensions.
- (c) Coil springs, shock absorbers, anti-roll bars and steering rack are free providing they fit to the same original locations.
- (d) Wheel off-sets may be varied to alter track dimensions by a maximum of 3 inch.
- (e) All transmissions in production before 1st January 1974 in FF are permitted.
- (f) Make and type of drive shaft is free.
- (g) The number, type and location of radiators is free.

### 5.4.4 MISCELLANEOUS

- (a) Cars may be updated to the specification of the latest model built by the manufacturer which appears in the list of eligible vehicles (e.g. Merlyn Mk1 1A up to Mk24 specification).
- (b) ELIGIBLE CARS if built prior to 1st. January 1974
  - Alexis Mk 1 4B to 24B Cougar
  - Crossle 1 6F & 20F DRW Mk8
  - Dulon LD4, LD4A to LD4C, LD9, MP15 & MP1 5B
  - Eldon Mk8, Mk10 to 1 0C Ginetta G18, G1 8B Hamlen Ff69
  - Hawke DL2A, DL2B, DL9, DL10, DI11
  - Huron FF Image FF1 Jamun T2, T3 Jomic Mk2A Jomo
  - Lola Mk5A, T200, T202, T204 Lotus 51, 61, 61M, 61R, 61X, 69
  - Macon Matek McNamara
  - Merlyn Mk9, Mk11A, Mk17, Mk17A, Mk20A, Mk24
  - Mirage M5 Mistrale
  - MRE FF72, FF73 U2 Mk9
  - Nike Mk10B (prior to 1.1.74) Nomad KH/FF16



## SRI LANKA AUTOMOBILE SPORTS

FURTHER IMPROVEMENTS AND UPGRADING TO THE REGULATIONS WILL BE FORMULATED IN ACCORDANCE TO THE RACE YEAR 2019 AND IMPLEMENTED IN 2020.

ALL SUPPORTING DOCUMENTS CAN BE DOWNLOADED VIA  
[www.slas.lk](http://www.slas.lk)