

# SOUTHERN ELIYAKANDA HILL CLIMB 2019

*At Brown's Hill, Matara*  
On Sunday 17<sup>th</sup> February 2019

A ROUND OF SLAS NATIONAL CHAMPIONSHIP 2019

Organized & Conducted By



## SOUTHERN MOTOR SPORTS CLUB MATARA

Organizing for the 23<sup>rd</sup> consecutive Year  
(Inaugurated On 21.12.1997)

**Supplementary Regulations**

*Version 1.2*

## **ANNOUNCEMENT**

Southern Eliyakanda Hill Climb 2019, is a Hill Climb race meet which is inscribed in the National Calendar of Sri Lanka Automobile Sports (hereafter, SLAS) for year 2019 and a round of SLAS National Championship 2019. This will run in accordance with the National Sporting Code (hereafter, NSC) of the SLAS its latest appendices, the Sporting Code of the Federation of Motor Cycle Sports in Sri Lanka (for motor cycles) and these Supplementary Regulations. Ignorance of any of these rules, regulations and codes will not be accepted as an excuse for violation and/or non-compliance.

Modifications, amendments and/or changes to these Supplementary Regulations will be announced only by numbered and dated bulletins (issued by Organizers or the Stewards)

## INDEX

ANNOUNCEMENT .....	1
INDEX .....	3
1. PROGRAMME .....	4
2. DESCRIPTION OF THE EVENT .....	4
3. PROMOTERS .....	5
4. ENTRIES.....	7
4.1 Entry Procedure .....	7
4.2 Eligible vehicles, Groups and Classes:.....	7
Motor Cycles.....	7
Motor Cars.....	8
4.3 Entry Fees (Including Buffet Lunch per Entry) .....	9
5. SLAS NATIONAL CHAMPIONSHIP 2019 .....	10
6. ELIGIBLE COMPETITORS.....	10
7. LIABILITY AND INSURANCE .....	11
8. SAFETY REQUIREMENTS .....	11
9. SPECIFICATION OF VEHICLES .....	11
10. COMPETITION NUMBERS & ORGANIZER’S STICKERS .....	12
11. RESERVATIONS AND OFFICIAL TEXT .....	12
12. START NUMBERS .....	13
13. STARTING ARRANGEMENTS .....	13
14. ADVERTISING .....	13
15. FLAG SIGNALS IN OPERATION.....	14
16. SCRUTINEERING.....	14
17. START, FINISH, TIMEKEEPING .....	14
18. PADDOCKS .....	15
19. ADDITIONAL CHECKS .....	16
20. PROTESTS.....	16
21. COMPETITOR UNDER THE INFLUENCE OF ALCOHOL OR DRUGS.....	16
22. PRIZES AND AWARDS .....	17

## 1. PROGRAMME

1. Opening of Entries at 10:00 hrs, Wednesday, 17<sup>nd</sup> of January 2019.
2. Closure of Entries at 17:00 hrs, Wednesday, 11<sup>th</sup> of February 2019.
3. Supervised practice will be held on Saturday 16<sup>th</sup> February 2019 from 7am to 1pm, maximum of two runs per one entry after a payment of Rs. 1,000/= per run.
4. Scrutinizing at 07:30 hrs, Sunday, 17<sup>th</sup> February 2019.
5. All competitors should report to the Chief Paddock Marshal at 07:00 hrs on 17<sup>th</sup> Sunday February 2019.
6. Official Start at 09:00 hrs, (Ascent with 2 runs), Sunday, 17<sup>th</sup> February 2019.
7. Finish of the Race at 15:00 hrs, Sunday, 17<sup>th</sup> February 2019.
8. Prize Giving at 16:00 hrs, Sunday, 17<sup>th</sup> February 2019.

## 2. DESCRIPTION OF THE EVENT

- |                        |  |
|------------------------|--|
| 9. Name                | : <b>Southern Eliyakanda Hill Climb 2019</b>   |
| 10. Place              | : Brown's Hill, Matara, Sri Lanka              |
| 11. Date               | : Sunday, 17 <sup>th</sup> February 2019       |
| 12. Status             | : National (As described in the NSC of SLAS)   |
| 13. Nature of the Meet | : Hill Climb (As described in the NSC of SLAS) |
| 14. Circuit Surface    | : Tarmac                                       |

### 3. PROMOTERS

Promoter's Name	: SOUTHERN MOTOR SPORTS CLUB (www.smsc.lk)
Address & Contact Details	: The Reliable Motor Agency, # 55, Kumarathunga Mw, Matara Tel: 041-2222330 Fax 041-2222330: 0777-225555, 070-2222699,
Stewards of the Meeting	: SMSC - Mr. Dimuth Bambarawanage - Mr. Jayaraj Wijeyaweera : SLAS - Mr. Anil Jayakodi : FMSSL - Mr. T. Ragunadhan
Race Director	: Mr. Ashhar Hameem
Clerk of the Course	: Mr. Andrew Silva, #55, Main Street, Matara. Tel 071-4045132
Deputy Clerk of the Course	: Mr. Nusky Iqbal
Secretary of the Meet	: Mr. Sarindu Gamage, #55, Main St, Matara. Tel. 077-6648889
Race Support Services Chief	: Mr. Prasanna Wijewickrama
Deputy Race Support Service	: Mr. Gihan Lahandapura
Chief Starters	: Mr. S. K. Methunsanka
Start line Marshals	: Mr.S. K. Kisal/ Mr. Malith Gayantha
Chief Paddock Marshal	: Mr. Chamila Wellakkage
Deputy Paddock Marshal	: Mr. Pawan De Silva/ Mr. Eranda Wakishta
Down Paddock Marshals	: Mr. Nadun Uluwita/ Mr. Brian Floyd/ Mr. Hiran Siriwardane/ Mr. Chanuka Ravishka/Mr.Upali Gamage/ Mr. Ganesh Jayawardane
Upper Paddock Marshals	: Mr. L. H. Rasika/ Mr. Jayawardane/ Mr. Gamage/ Mr. Thilina
Dummy Grid Chief	: Mr. Dakshina Ariyaratna
Deputy Dummy Grid Chief	: Mr. Kelum Buddika/ Mr. Nuwaizer Deen
Dummy Grid Assistants	: Mr. Suranga Pradeep Kumara/ Mr. Chathuranga Nanayakkara
Welfare Officers	: Mr. Damith Gajamange
Technical Equipment Chief	: Mr. Lahiru Samarawickrama
Technical Equipment Assistant	: Mr. Pramith Salwathura
Competitor Liaison Officer	: Mr. Amila Sapukotana
Chief Corner Marshal	: Mr. Sandaru Dheeraseskara
Deputy Chief Corner Marshal	: Mr. Haridu Nath Liyanage

Corner Marshal	: Mr. Pramith Salwathura/ Mr. Janith Nimantha/ Mr.Monty Uluwita/ Mr. Chamara Wedage/ Mr. Kumudith Wanigasekara/ Mr. Harith Palihakkara/ Mr. Samesh Nimadh/ Mr.Banura Liyanage/ Mr.Dishan Salgado/Mr. Kaveen Salgado / Mr. Sakindu Benul/ Mr. Madhawa Ranasinghe
Chief Time Keeper	: Mr. Rahal Uluwita
Time Keeper	: Miss. Deewani Liyanage/ Miss. Ruwini De Silva/ Miss. Okandi Wijewickrama/ Mr.Naveed Bawa
Back Up Time Keepers	: Mrs. Ashanthi Liyanage/ Mr. Malith Dassanayake/ Mr. Thiwanka Gunawardane
Chief Result Co-Ordinator	: Mr. Shihan Samsudeen
Deputy Result Co-Ordinator	: Miss. S. K. Amanda
Scrutinize Office	: Mr. Nalaka Abeygunawardana/ Mr. Loyd Pearson
Chief Scrutinizers – Cars/Bikes	: Mr. Ryan Grey/ Mr. Ziafudeen
Car - Scrutinizer	: Mr. Saman Bandaranayake/ Mr. Samantha Wehella/ Mr. Miyuru Samarawickrama/ Mr. Siril Gajanayake
Scrutinizers - Bikes	: Mr. Indika Gurusinghe/ Mr. Ivon Gurusinghe/ Mr. Bhagya Ranahansa
Medical Officers	: Dr. Susantha Paaris
Chief Recovery Officer	: Mr. Monty Uluwita/ Mr. Athula Wickramasurendra
Crowd Controlling	: Mr. Indunil Sandaruwan/ Mr. Prasanna Liyanage
Emergency Incident Officer	: Mr. Dishan Goonasekara
Chief Safety Officer	: Mr. S. M. P. Jinnapriya
Award Ceremony Coordinator	: Mr. Ramesh Malanga
Administration Head	: Mr. Nuwan Samarawickrama
Race Office	: Mr. Gayan Samarawickrama/ Mr. Amila Sapukotana / Mr. Gihan Lahandapura/ Mr. S. M. P. Jinappriya
Sponsorship Coordinator	: Mr. Ashhar Hameem
Car Competitors Coordinator	: Mr. Prasanna De Alwis
Motor Cycle Coordinator	: Mr. Sudath Weerasinghe
Weigh Marshal	: Mr. Pasindu Bandaranayake / Mr. Buwaneka Bandaranayake

## 4. ENTRIES

### 4.1 Entry Procedure

Those wishing to take part in the “Southern Eliyakanda Hill Climb 2019” must send the enclosed entry form, duly completed, to any of the following addresses,

- The Reliable Motor Agency # 55, Kumarathunga Mawatha, Matara  
Tel: 041-2222330 Fax 041-2222330
- MARBLE DECOR , 175, Nawala Road, Nugegoda (Nishantha) - 0777 910165  
Tel: 011-7254455, Fax. 011-2820155
- [www.smsc.lk](http://www.smsc.lk)> Online Application / Downloadable Application

The onus of ensuring that the Entry Form is received at the above addresses, and in time, rests with the Entrant/Driver/Rider. The Entrant/Driver/Rider is held entirely responsible for ensuring that his vehicle conforms to the declarations made in his/her Entry Form. Any deviation detected could result in exclusion from the Meet and/or further disciplinary action.

***Maximum Number of Entries per one Competitor:***

Any competitor can take part in **NOT MORE THAN FIVE CLASSES/GROUPS** Within this Meet.

***Sharing of Competition Vehicles:***

Any competition vehicle can be used by **NOT MORE THAN THREE COMPETITORS**.

Acceptance of an Entry is at the sole discretion of the General Committee of the Southern Motor Sports Club.

### 4.2 Eligible vehicles, Groups and Classes:

Motorcycles as defined in **Appendix "C"** of the Sporting Code of the FMSSL and Automobiles as defined in **Appendix "G"** to the SLAS, N.S.C and as specified below will be eligible to enter.

#### Motor Cycles

**GROUP O - TARMAC CIRCUIT / HILL CLIMB**

1. Standard Motorcycles – Over 100cc up to 125 cc – 4T (Mono Cylinder Air Cool) Open for Novices.
2. Standard Motorcycles – Over 125 cc to 160 cc 4T

**GROUP M – TARMAC CIRCUIT / MOTOCROSS / HILL CLIMB**

3. Standard / Modified Motorcycles – Over 100cc up to 125 cc 2T
4. Standard / Modified – Over 175cc Up to 250 cc 4T – Super Sport

5. Standard/Modified – Over 400cc Up to 600cc 4T
6. Standard/Modified – Super Sport Motorcycle Over 900 cc Up to 1000cc 4T
7. Standard / Modified Street Trail Motorcycles – Over 175cc up to 250cc4T
8. Sports Touring Motor Cycle – Over 700cc
9. One Make Motor Cycle – Kawasaki Tracker 250cc 4T
10. One Make Motor Cycle – Buel
11. Automatic Transmission Scooter – Over 90CC Up To 110CC

#### **GROUP MX – MOTOCROSS / HILL CLIMB**

12. Racing Motorcycles – Over 65cc Up to 85 cc (2T)
13. Racing Motorcycles – Over 175cc Up to 250 cc 4T & Over 100cc Up to 125 cc 2T.
14. Racing Motorcycles – Over 175cc Up to 250cc 2T and Over 249cc Up to 450cc 4T

#### **GROUP SUPER SM – SUPERMOTO / SUPERMOTARD**

15. Motorcycles – Over 100cc Up to 125 cc 2T & Over 175cc Up to 250 cc 4T
16. Motorcycles – Over 175cc up to 250 cc 2T& Over 249cc up to 450 cc 4T

If at least 7 entries are not received for a particular event in the above classes, that event will not run.

### **Motor Cars**

#### **1. Group N Production Cars**

- 1.1. Ford Laser / Mazda 323 up to 1500 cc - BD, BE, BF Hatchbacks & Sedans

#### **2. Group F (FORMULA CARS)**

- 2.1. Formula McLarens 1300cc CARB
- 2.2. Formula McLarens 1300cc EFI
- 2.3. Formula Cars up to 1600cc (Ford Formula)
- 2.4. Formula Cars Modified (Up to 1665 cc)

#### **3. Group T&J (Trucks, Jeeps, Double Cabs, Single Cabs, SUV's. (Estates and station wagons are excluded).**

- 3.1. Diesel up to 5500 cc
- 3.2. Open for Diesel & Petrol Vehicles (SUV's Allowed).

#### **4. Group A (Modified Cars)**

- 4.1. up to 1050cc
- 4.2. Mini 7 – (One Make) – no upgrading allowed.

#### **5. Group H**

- 5.1. SL H Cars up to 1618cc (One make – Honda 3 door Hatch back Cars only)
- 5.2. Subaru Legacy cars up to 2000cc



**6. Group GT (Grand Touring Cars) (Engine interchange allowed as per SL-H regulations)**

6.1. Up to 3500 cc

**7. Group E (Group E)**

7.1. Cars up to 1000CC – one make Nissan March (Entry Level)

7.2. Ford Laser/ Mazda 323 up to 1300cc – BD, BE, BF Hatch backs &amp; Sedans (Entry Level)

7.3. Mini up to 1275 – One Make (Entry Level)

**8. Group S (Group S)**

8.1. Cars up to 1500cc

It if at least 5 entries are not received and not present at least 4 starters for a particular event in the above classes, that event will not run. (Final Decision will be given by SMSC)

\*\*\* SLAS Regulations can be Viewed & Downloaded from the SLAS Official website:  
<http://www.slas.lk/> \*\*\*

**4.3 Entry Fees (Including Buffet Lunch per Entry)**

	<u>Members of SMSC, YSMSC</u>	<u>Non-Members</u>
Motor Cars	Rs. 4,000/=	Rs. 5,000/=
Motor Cycles	Rs. 2,000/=	Rs. 3,000/=
Account Details: Bank Name	: Pan Asia Bank PLC – Matara	
Account Name	: Southern Motor Sports Club	
Account Number	: 101311000195	

Supervised Practice Motor Cars / Bikes **Rs.1000/= per Run** (Maximum two Runs Per Entry)  
Practices will be held on Saturday 16<sup>th</sup> February from 7.00am to 1.00pm

The competitors participating in the Hill Climb will be provided with lunch, free of charge. Lunch for additional persons can be obtained at the rate of Rs. 1500/- per person.

**“Refunds”**

Entry Fees will be refunded in full only:

- To Candidates whose entry has not been accepted.
- In the case of the Meet not taking place.

## 5. SLAS NATIONAL CHAMPIONSHIP 2019

5.1 Following Events will be run under SLAS National Championship 2019 (To Eligible for the National Championship Event minimum number of entries required as per Appendix G)

1. Formula McLarance –1300cc Carb – Junior National
2. Nissan March 1000cc One Make
3. Mini 1275cc One Make
4. Ford Laser/Mazda – 1300cc
5. Formula McLarance –1300cc EFI
6. SL A up to 1050cc
7. Mini Seven
8. Ford Laser/Mazda – 1500cc
9. SL H – Subaru One Make
10. SL H – 1600cc
11. SL S – 1500cc
12. SL GT – 3500cc
13. Ford Formula – 1600cc

## 6. ELIGIBLE COMPETITORS

This is a National Competition and, is open to all nationals/residents of Sri Lanka provided they conform to the following requirements:

- If he/she is a bona-fide driver who is an amateur holding a valid Competition License issued by Sri Lanka Automobile Sports. In the case of Motorcyclists, he/she must have a valid Certificate of Competence issued by the FMSSL (Federation of Motorcycle Sports in Sri Lanka)
- If he/she is not under a sentence of General Suspension of the Sri Lanka Automobile Sports or the Internal Suspension of the Southern Motor Sports Club.
- If he/she is not suffering from any mental or physical disability
- If being a minor under the age of 21 years, he/she produces at the time of forwarding his/her Entry, a letter of specific consent from his/her parent or guardian.

### **Condition for Acceptance of Entry**

All Entries received will be considered by the Organizing Committee with regard to the suitability of the vehicle and Driver/Rider. The Organizing Committee may in its absolute discretion, refuse to accept an entry or vehicle without assigning a reason for refusal and their decision shall be final and shall not be questioned in any forum.

Competitors participating at this Meet do so entirely at their own risk and in the event of an accident absolve the Southern Motor Sports Club, the Organizing Committee, Race Officials, Sri Lanka Automobile Sports (SLAS), and The Federation for Motor Cycle Sports in Sri Lanka (FMSSL) from any liability arising due to such accidents, however caused.

## 7. LIABILITY AND INSURANCE

- a. Each participant shall take part in the meet on his/her own risk. The organizer shall refuse to accept any liability or personal injury or damage to property vis-à-vis competitors, drivers, assistants, and third parties.
- b. Each competitor shall be held responsible for his/her own insurance.
- c. The Promoter will arrange for competitors and officials to be covered against 3rd Party Civil Liability Risks on the day of Meet, whilst on the course.

## 8. SAFETY REQUIREMENTS

### 8.1 Protective gear

Drivers Protective gear will be as per SLAS Appendix G on “Minimum Safety Standards”.

### 8.2 Other safety measures

Safety requirement of the competition vehicle will be as per **SLAS Appendix G**.

\*\*\* SLAS Regulations can be Viewed & Downloaded from the SLAS Official website:

<http://www.slas.lk/> \*\*\*

## 9. SPECIFICATION OF VEHICLES

- 9.1. Technical specification for Group N, A, H, E, S, T & J, GT and Specific Rules for One make classes, please refer the **Appendix G of SLAS**
- 9.2. In every case where a minimum weight has been specified, it is the duty of the competitor to ensure that at any time during the meet, the weight of the vehicle will not be less than the minimum weight. It is permitted to carry ballast as a means of achieving the minimum weight provided that the ballast is of solid material and is attached to the vehicle in a safe manner with provisions for placing of seals by the scrutinizers. Maximum of 0.01% variance will be given **sole discretion of** the marshal .
- 9.3. The reference weighing scale is the SMSC Scale. The Scale will be available on 17<sup>th</sup> February at the Finish Area (GA’s Residency).

## 10. COMPETITION NUMBERS & ORGANIZER'S STICKERS

Competition numbers & Race Plates (Bonnet & Rear Side windows – As per the diagram shown below) provided by the organizers are compulsory for all competitors. Following space is reserved in competition vehicle for organizers advertisements. If a competitor is not willing to display optional advertisements as referred below he / she should pay an additional Rs.15,000/- in cash.

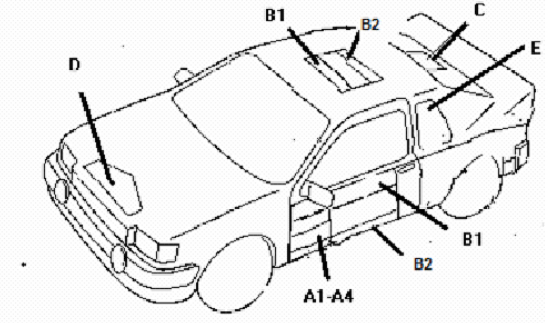

The advertising (A/B) is as follows:

- A1 - A4: Competition Number
- B1 - B2: Compulsory Advertisements
- C: Rear Window Plate
- D: Competition Number (on bonnet)

## 11. RESERVATIONS AND OFFICIAL TEXT

- 11.1.** Organizers reserve the right to add/modify this supplementary regulation or to issue additional conditions or instructions which will form an integral part of them. However, these amendments will be issued only after ratification by the SLAS or Stewards of the meet. Also reserves the right to cancel or stop the meet in the case of insufficient participation, force majeure or unforeseeable events, without being under any obligation whatsoever to provide compensation.
- 11.2.** Participants shall be informed of any amendments or additional conditions as soon as possible.
- 11.3.** Any cases not provided for in the supplementary regulations shall be decided by the Stewards of the Meeting.

## 12. START NUMBERS

- 12.1. The organizer shall provide each participant with a set of start numbers, which shall be clearly displayed on both sides of the vehicle and on the bonnet, throughout the duration of the meet. Vehicles without correct start numbers will not be allowed to start the event.
- 12.2. The organizer shall be responsible for allocating the start numbers.

## 13. STARTING ARRANGEMENTS

- 13.1. Competitors should first report to the race headquarters located at the track and only then proceed to scrutineering.
- 13.2. After scrutineering, the competitors must park their vehicles in the Paddocks. The competitors must not leave the Paddocks unless they are instructed to do so by the Chief Paddock Marshal.
- 13.3. The events of a meet will be run according to the official program, unless varied by the Clerk of the Course in consultation with the stewards of the meeting.
- 13.4. The drivers shall accept the consequences should they be unaware of any conditions or modifications to the timetable which might be decided prior to the start.
- 13.5. The participants shall take their place in the starting line at least 10 minutes prior to their starting time. Any driver who fails to report to the start at his scheduled starting time may be excluded from the event.

## 14. ADVERTISING

- 14.1. Any advertising may be affixed to the vehicles, on the condition that;
  - It complies with the SLAS and FMCSSL regulations.
  - It is not offensive.
  - No advertising whatsoever may be affixed to the side windows.
- 14.2. The only obligatory form of advertising shall be that appear on the start numbers.

## 15. FLAG SIGNALS IN OPERATION

15.1. Only the following flag signals will be in operation at the Meet.

**RED FLAG** : Stop Immediately

**YELLOW FLAG** : Caution! Take care, track may be slippery, damaged or there may be obstacles on or beside the track.

**GREEN FLAG** : Track Clear

## 16. SCRUTINEERING

- 16.1. Scrutineering of vehicles is compulsory and will commence at 06:30 am on 16<sup>th</sup>(Practice Day Participants only) and 17<sup>th</sup> February 2019 at Paddocks located closer to the racetrack Brown's Hill, Matara. Any vehicle failed by the Chief Scrutinizer will not be allowed to compete.
- 16.2. Participants are obliged to accompany their vehicle at scrutineering, so that identification and safety checks can be carried out.
- 16.3. Participants reporting for scrutineering after their scheduled time shall be liable to a penalty which may go as far as exclusion, at the Steward's discretion. However, the stewards may decide to allow the vehicle to be scrutinized if the competitor/driver can prove that their late arrival was due to force majeure.
- 16.4. Scutinizing does not constitute confirmation that the vehicle complies with the regulations in force.
- 16.5. At the conclusion of the Meet, all vehicles will remain in Paddocks in the custody of the Chief Scrutinizer for one hour. Any Competitor's vehicle leaving the Paddocks during this period without written permission of the Stewards is liable to disqualification in the event of a protest.
- 16.6. The attention of all Competitors is drawn to the Steward's right to have a competing vehicle dismantled and measured even in the absence of a protest.

## 17. START, FINISH, TIMEKEEPING

- 17.1. In the case of both Motor Cycles and Motor Cars, the engines will be running at the Start. Vehicles will start individually from the Start Line, strictly according to the positions held at the Start during lining-up by Start Line Marshals.
- 17.2. A Competitor shall be deemed to be under Starter's Orders once he is called up for competition by Paddock Marshal.
- 17.3. Any Competitor who is absent from the Paddocks when required by the Paddock Marshal to be placed under Starter's Orders or who refuses to start when required to do so by the

- Starter, will forego that run. On leaving the Paddocks, the competitors will strictly follow the instructions given by officials for proceeding to the Start and for lining-up.
- 17.4. The Stewards of the Meeting and the Clerk of the Course are free to modify the starting order according to the circumstances.
  - 17.5. No vehicle may take the start outside its own group unless expressly authorised to do so by the Stewards of the Meeting.
  - 17.6. Any vehicle which has triggered the timing apparatus shall be considered as having started, and shall not be granted a second start.
  - 17.7. Any refusal or delay in starting shall result in exclusion.
  - 17.8. The finish shall be a flying finish. The heat ends when the vehicle crosses the finish line, as soon as this is done, the vehicle must reduce speed drastically.
  - 17.9. Timing of each run of each competitor will be done with the aid of Electronic Timing Equipment installed at the Start and the Finish. The infra-red beams sent by the timing are cut by the competing vehicle, recording the time taken for the run, to 1/100 of a second.
  - 17.10. All the competitors participating in the Hill Climb will be given two runs and the better of the timings of the two ascents of the competitors will count for the final result. If however, the Organizers are unable to give an opportunity for some competitors to have a second run, in such case, the final result will be determined by the times returned by all competitors in such class on their first run. The competitor in each class, who is the fastest on meet day will be adjudged the Winner for his class.
  - 17.11. Re-runs will be allowed at the **sole discretion of the Clerk of the Course**. Usually re-runs are approved only in the event of timing equipment failure.
  - 17.12. Competitors are allowed to inspect the tract (without the vehicle). Any form of practicing on the course itself and the Paddock area is STRICTLY PROHIBITED. **This will result to ban the competitor from the entire race meet**.

## 18. PADDOCKS

- 18.1. Paddocks will operate from 07.30 am on 17-02-2019 and all vehicles are required to be in Paddocks prior to the commencement of events.
- 18.2. At the end of the event, all vehicles shall remain in Paddocks until indication to the contrary is given by the clerk of the course with the approval of the stewards and until the period of time allowed for the lodging of protests has expired.

## 19. ADDITIONAL CHECKS

- 19.1. Any vehicle may be subject to additional checking by the scrutinizers, both while the event is taking place and especially after the finish.
- 19.2. At the request of the Stewards, whether spontaneously or following a protest, a vehicle may be impounded after the finish and subjected to complete and detailed scrutineering entailing the dismantling of the vehicle.

## 20. PROTESTS

- 20.1. All protests shall be made in writing in accordance with the provisions stated in National Sporting Code Part XII of the Sri Lanka Automobile Sports.
- 20.2. Written protests shall be handed over to the Clerk-of-the-Course or to his Deputy, or in the absence, to the Secretary of the meet, with protest fees, for onward transmission to the Stewards of the Meet, within 30 conclusion of the meet(Not the price Giving).
- 20.3. The protest fee is Rs.15,000/- in cash and must accompany the written protest.
- 20.4. An additional initial deposit of Rs.50,000/- by cash shall be kept by the person lodging the protest if, the protest requires to dismantle a competition car. However, if the protest is upheld the deposit will be refunded to the protestor and the entire expense will be recovered from the competitor in concern and if the protest is not upheld deposit will not be refunded and any additional cost, if there are will also be recovered from the protestor.
- 20.5. Any competing vehicle may be impounded by the Organizing Committee at the conclusion of the event. Any such impounded vehicle will only be released after all phases of examination are complete. The impounded vehicle will be dismantled for examination at a place decided by the Organizing Committee and under the supervision of the Committee.
- 20.6. No protest over **official time-keeping or manner of conducting the meet** will be considered or accepted.

## 21. COMPETITOR UNDER THE INFLUENCE OF ALCOHOL OR DRUGS

Any Competitor found to be under the influence of liquor and drugs will not be permitted to participate in the Meet. A Competitor shall if so request by the Clerk of the Course, undergo an examination by a Medical Officer in attendance, which may also include a Breathalyser Test. The Medical Officer's decision and/or the results of the Breathalyser Test will be taken as final and binding on the Competitor. Refusal to submit to medical examination as above will result in automatic exclusion of such Competitor from the Meet.



## 22. PRIZES AND AWARDS

Trophies and Certificates will be awarded to those placed 1st, 2nd and 3rd in each class. And ***Preethi Palliyaguru Challenge Cup*** will be awarded to the competitor recording the fastest time for the day in Southern Eliyakanda Hill Climb. In addition, special trophies will be awarded to the competitors recording the fastest time for the day for motor cycles and motor cars.

Email: [info@smc.lk](mailto:info@smc.lk), [smc\\_srilanka@yahoo.com](mailto:smc_srilanka@yahoo.com)

Hot Lines 071-4045132, 077-6648889, 0777-225555. 070-2222699

Web site : [www.smc.lk](http://www.smc.lk)